

Chiller and Inverter Air/Water heat pumps with axial fan

## Technical Bulletin

### Model

i-32V5H MIDI 0121

i-32V5H MIDI 0126

i-32V5H MIDI 0128

i-32V5H MIDI 0132



This manual has been created for informative purpose. The company declines any responsibility for the results of any projecting or any installation based on the explanations and/or on the technical specifications provided in this manual. It is besides forbidden the reproduction under any form of the texts of the figures contained in this manual. This manual is a translation from the official italian language version. For reasons of environmental respect the Company will not provide the hard copy in the original language which could be directly requested or downloaded from the Company website at any time. In case of any dispute, the original language manual will be the trusted one. Even partial reproduction PROHIBITED © Copyright - Advantix SpA

00	01-2021	EM	AR	First emission
Rev	Date	Compiled	Approved	Note
Code				Serie
BTE01040101001.00_i-32V5 Midi_EN				Chiller and Inverter Air/Water heat pumps with axial fan

**Contents**

1.DESCRPTION OF UNIT AND TECHNICAL SPECIFICATIONS ..... 5

1.1 FRAMEWORK..... 5

1.2 COMPRESSORS ..... 5

1.3 AIR SIDE HEAT EXCHANGER ..... 5

1.4 UTILITY SIDE HEAT EXCHANGER ..... 5

1.5 FAN ..... 5

1.6 COOLING CIRCUIT..... 5

1.7 ELECTRICAL AND CONTROL PANEL ..... 6

1.8 CONTROL AND PROTECTION DEVICES..... 7

1.9 HYDRAULIC CYRCUIT ..... 7

2.DESCRPTION OF VERSIONS AND ACCESSORIES ..... 7

2.1 VERSIONS ..... 7

2.2 LIST OF ACCESSORIES ..... 8

2.3 DESCRIPTION OF ACCESSORIES ..... 9

2.3.1 Factory-fitted accessories..... 9

2.3.2 Accessories supplied separately..... 9

3.INSTALLATION ..... 11

3.1 UNIT DIMENSIONS, HYDRAULIC CONNECTIONS, WEIGHTS AND CENTRE OF GRAVITY POSITION ..... 11

3.1.1 Net dimensions and with packaging ..... 11

3.1.2 Detail of connections and location ..... 12

3.1.3 Weights ..... 12

3.1.4 Location of the centre of gravity and vibrations dampers..... 12

3.2 TECHNICAL SERVICE AREAS ..... 13

3.3 HYDRAULIC CIRCUIT ..... 15

3.3.1 System water specifications ..... 16

3.3.2 Typical hydraulic scheme ..... 16

3.3.3 Hydraulic diagram inside the unit ..... 17

3.3.4 Minimum water content and hydraulic circuit volumes..... 18

3.3.5 Condensate drainage system..... 18

3.3.6 System charging/discharging..... 19

3.3.7 Air vent valve..... 19

4.TECHNICAL DATA ..... 20

4.1 HEAT PUMP DATA SHEET ..... 20

4.2 DATA SHEET UNIT WITH DESUPERHEATER ..... 21

4.3 UNIT AND AUXILIARY ELECTRICAL DATA..... 22

5.CORRECTIVE FACTORS ..... 22

5.1 CORRECTION FACTORS FOR USE OF WATER-GLYCOLE MIXTURE ..... 22

5.2 SCALING CORRECTION FACTOR ..... 22

5.3 CaLIBRATIONS AND PROTECTIONS CONTROL..... 22

5.4 CORRECTION FACTORS DEPENDING ON ALTITUDE ..... 23

6.HYDRONIC GROUP DATA DATI DEL GRUPPO IDRONICO ..... 24

6.1 USEFUL HEAD ..... 24

6.2 PRESSURE DROP Y-FILTER ACCESSORIES 3-WAY VALVE ..... 24

6.3	CIRCULATOR/PUMP CURVES .....	25
7.	SOUND EMISSIONS.....	26
7.1	POWER AND SOUND PRESSURE STANDARD .....	26
8.	OPERATING LIMITS .....	27
8.1	WATER FLOW RATE AT THE EVAPORATOR .....	27
8.2	CHILLER WATER PRODUCTION (SUMMER OPERATION) .....	27
8.3	HOT WATER PRODUCTION (WINTER OPERATION) .....	27
8.4	AMBIENT AIR TEMPERATURE AND SUMMARY TABLE .....	27
9.	PERFORMANCE TABLES .....	29
9.1	HEATING .....	29
9.2	COOLING.....	30
9.3	SANITARY .....	31
9.4	DATA FOR ENERGY CERTIFICATION OF BUILDINGS ACCORDING TO UNI/TS 11300-4 FOR HEAT PUMPS.....	32
9.4.1	Model i-32V5H MIDI 0121.....	32
9.4.2	Model i-32V5H MIDI 0126.....	33
9.4.3	Model i-32V5H MIDI 0128.....	33
9.4.4	Model i-32V5H MIDI 0132.....	34
9.5	EER VALUES FOR CALCULATING THE ENERGY PERFORMANCE OF BUILDINGS ACCORDING TO UNI/TS 11300-3.....	36
9.5.1	Model i-32V5H MIDI 0121.....	36
9.5.2	Model i-32V5H MIDI 0126.....	36
9.5.3	Model i-32V5H MIDI 0128.....	37
9.5.4	Model i-32V5H MIDI 0132.....	37
10.	REFRIGERANT SAFETY SHEET.....	38

## 1. DESCRIPTION OF UNIT AND TECHNICAL SPECIFICATIONS

The heat pumps in this series were designed for residential and commercial applications. They are extremely versatile and are designed for heat pump operation with hot water production for space heating and sanitary use at a temperature of 60°C. The use of the brushless inverter compressor technology, combined with the electronic expansion valve, the circulator and the variable speed fan, optimise the consumption and operating efficiency of the cooling components.

### 1.1 FRAMEWORK

Structure suitable for outdoor installation consisting of thick profiles made of hot galvanised sheet steel and painted with polyester powder, colour RAL 7035 textured, resistant to atmospheric agents. The removable panels allow maintenance inside the refrigeration and hydraulic circuits.

### 1.2 COMPRESSORS

Twin rotary hermetic inverter controlled DC compressors, specifically designed to operate with R32, equipped with thermal protection and mounted on rubber vibration dampers.

This component is installed in a compartment separate from the air flow to reduce noise and is equipped with a crankcase heater that prevents the dilution of the oil by the refrigerant, ensuring correct lubrication and reducing wear on moving parts.

The compressors can be inspected by removing the side and front panels of the unit, allowing maintenance even when the unit is running.

### 1.3 AIR SIDE HEAT EXCHANGER

The air exchangers are made of copper tubes and aluminium fins. The pipes are mechanically expanded in the aluminium fins to increase the heat exchange factor. The geometry of these exchangers allows a low value of pressure losses on the air side and therefore the possibility of using fans with a low number of revolutions (with a consequent reduction in machine noise).

On request, the coils can have surface treatments to allow greater resistance to corrosion or be made entirely of copper with a brass structure.

### 1.4 UTILITY SIDE HEAT EXCHANGER

Brazed plate heat exchanger made of AISI 304 stainless steel, covered with black flexible closed-cell elastomeric foam; thickness 9 mm, thermal conductivity ( $\lambda$ )  $\leq 0.036$  W/mK (at air +20°C). A flow switch installed on the water side ensures the presence of water flow and, together with the protection probe, prevents the formation of ice inside.

The exchanger can be equipped with an electric antifreeze heater (optional accessory KA1)

### 1.5 FAN

The fans are axial type with airfoil blades. They are statically and dynamically balanced and supplied complete with protection grille and air inlet and outlet with double flared profile, specially shaped to increase efficiency and reduce noise. The electric motor used is driven in modulation with brushless EC motor, directly coupled, and equipped with integrated thermal protection. The motor has an IP 54 protection rating according to CEI EN 60529.

### 1.6 COOLING CIRCUIT

The cooling circuit is made of copper piping, brazed and assembled in the factory in accordance with EN 13134. The components present are:

- Filter drier with 100% molecular sieve cartridge;
- Shut-off valve on the liquid line;
- Liquid flow and moisture indicator;
- Electronic expansive valve;
- Charge connections;
- High-pressure safety pressure switches;
- High and low pressure transducers;
- Reverse cycle valve;
- Receiver and liquid separator.

The suction line is thermally insulated with flexible, closed-cell elastomeric foam.

Each unit is pressure tested to check for leaks and is supplied complete with a refrigerant charge optimised for operation.

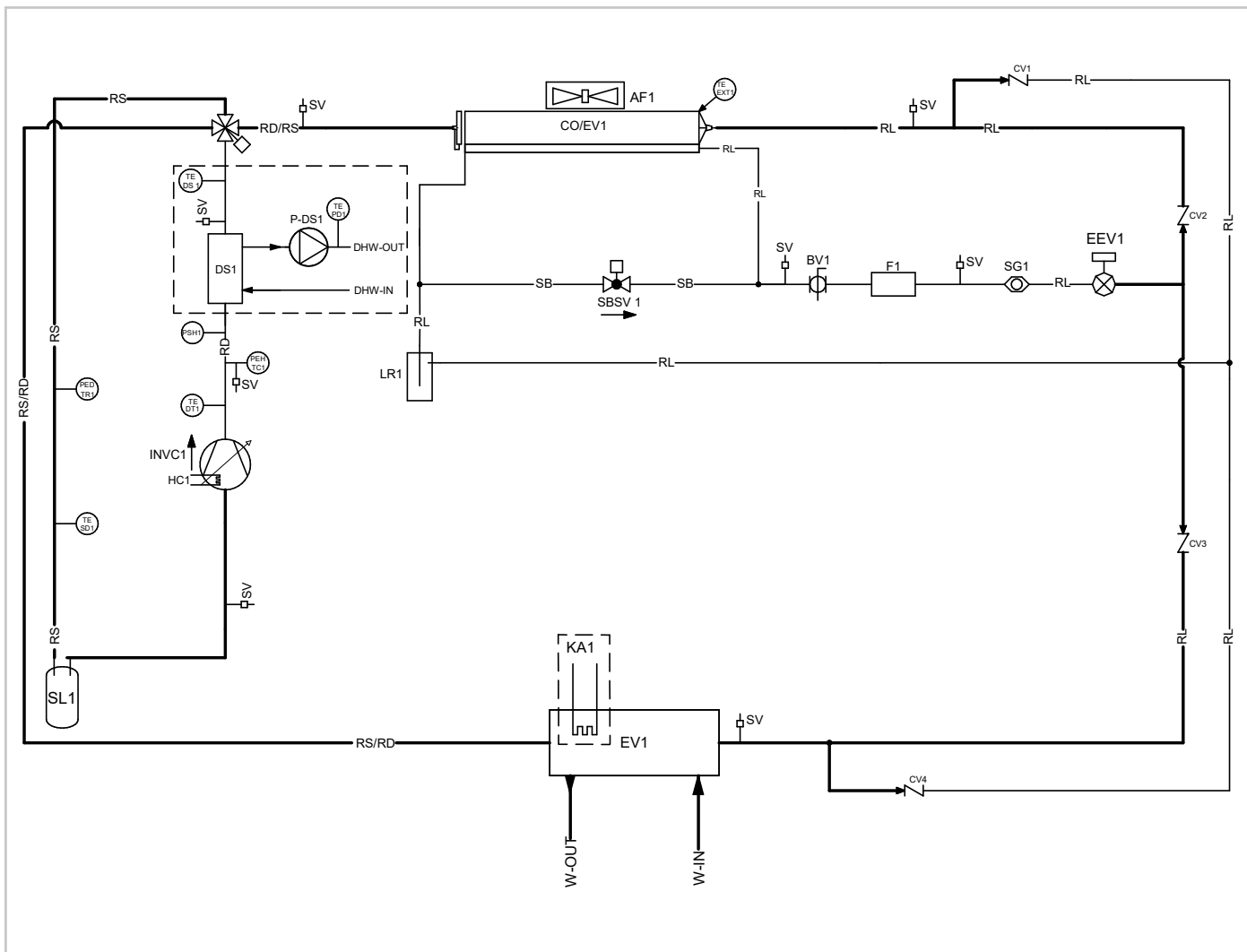

**LEGEND**

INVC	1	VARIABLE SPEED COMPRESSOR	SL	1	LIQUID SEPARATOR
CO/EV	1	FINNED BATTERY	YISV	1	4-WAY VALVE REVERSE CYCLE
EV/CO	1	PLATE EXCHANGER	SB		SUBCOOLING BYPASS LINE
EEV	1	ELECTRONIC EXPANSION VALVE	SBSV	1	BYPASS LINE SOLENOID VALVE
SV		CHARGING ATTACHMENT	SG	1	LIQUID AND MOISTURE INDICATOR
F	1	FILTER DRIER	PEH TC	1	HIGH PRESSURE TRANSDUCER
HC	1	CRANKCASE RESISTANCE	PED TR	1	LOW PRESSURE TRANSDUCER
AF	1	AXIAL FAN	PSH	1	HIGH-PRESSURE SWITCH
RD		DELIVERY LIVE	HKA	1	HEAT EXCHANGER ANTIFREEZE RESISTOR
RL		LIQUID LINE	TE SD	1	SUCTION TEMPERATURE PROBE
RS		SUCTION LINE	TE DT	1	EXHAUST TEMPERATURE PROBE
RS/RD		SUCTION/DELIVERY LINE	TE DS	1	TEMPERATURE PROBE (DS)
RD/RS		SUPPLY/SUCTION LINE	TE EXT	1	OUTDOOR AIR PROBE
BV	1	SPHERE VALVE	TE PD	1	DS WATER OUTLET TEMPERATURE PROBE
DS	1	DESUPERHEATER	W-DS-IN		DESUPERHEATER WATER INLET
P-DS	1	DESUPERHEATER CIRCUIT CIRCULATOR	W-DS-OUT		DESUPERHEATER WATER OUTLET
CV		NON-RETURN VALVE	W-IN		WATER INLET
LR	1	LIQUID RECEIVER	W-OUT		WATER OUTLET
---		ACCESSORY INSTALLED ON BOARD			

**1.7 ELECTRICAL AND CONTROL PANEL**

Completely manufactured and wired in accordance with IEC 60335-2-40.

The power section includes:

- Isolation transformer for control power supply;
- Thermal protection fuses for compressor driver and EC fan;
- Automatic switch for compressor protection (optional);
- Driver for modulating compressor control;

- Phase sequence control relays;
- Phase sequence control relay with minimum/maximum voltage setting (optional);
- Thermostatically controlled ventilation inside the electrical panel;
- GI module - system management. (optional or for versions that require it).

The control section includes:

- Interface terminal with alphanumeric display;
- Display function for set values, analogue inputs, fault codes, alarm history and parameter index;
- Key on/off and alarm reset;
- Key combinations to force defrost and force pump to maximum speed;
- Management of unit start-up from local or remote;
- ModBus connectivity (optional);
- BMS connectivity via converter
- BMS connectivity (ModBus/Bacnet/Knx/Lonworks) - optional.
- BMS connectivity (ModBus/Bacnet/Knx/Lonworks) - optional.

## 1.8 CONTROL AND PROTECTION DEVICES

All units are equipped as standard with the following control and protection devices: inlet water temperature probe installed on the water return pipe from the system, outlet water temperature probe that also functions as an anti-freeze probe installed on the water supply pipe to the system, high pressure transducer, low pressure transducer, compressor suction and discharge temperature probes, compressor thermal protection, fan thermal protection, flow switch on the water side to protect the evaporator, high pressure switch.

## 1.9 HYDRAULIC CYRCUIT

The units in the series are supplied with a built-in hydraulic circuit that includes: high-efficiency brushless motor modulating circulator (EEL≤0.23), suitable for the use of chilled water and directly controlled by the on-board control, plate heat exchanger, protection flow switch, safety valve (6 bar) to be connected to a collection system and manual air vent valve.

## 2. DESCRIPTION OF VERSIONS AND ACCESSORIES

### 2.1 VERSIONS

The available versions are:

**i-32V5H Midi - heat pump standard version**

**i-32V5H-DS Midi - heat pump with superheater**

The unit with desuperheater includes the addition of a brazed plate type heat exchanger made of AISI 316 stainless steel, factory insulated using closed cell material. This version allows to recover about 20% of the condensing heat otherwise lost and to use it to feed the after-heating water coils of an AHU or for a hot water flywheel or for any other process use.

**Attention: in the DS version is not possible to connect the domestic hot water tank remote probe**

**i-32V5H-BT Midi - chiller BT version (for low water temperature)**

The BT version of the unit allows the operating range of the unit to be extended by cooling the water supplied to the user down to -8°C. In this case, a mixture of water and glycol is used.

Order code	Unit version	Thermal capacity	Water pipe configuration	Injection (LT)	Silencing	Antifreeze kit accessory	System management module	Electrical variants	Accessory - battery treatment	Accessory 1	Code
0110820#	RV	CT1	TA	IV	SIL	KA	GI	EL3	TR	AC1	MC
	57 Reversible heat pump										
	55 BT version on heat pump										
	24 0121										
	25 0126										
	26 0128										
	27 0132										
		0 2 pipes									
		3 Desuperheater circuit									
			0 Without injection		0 No silencing	0 Without antifreeze kit					
						1 With antifreeze kit					
							0 Without GI/GI2*				
							1 With GI/GI2 plant operator				
							2 Modbus (CM)*				
							3 Modbus (CM) + GI				
								0 Standard			
								2 Thermomagnetic circuit breakers (IM)			
									0 No one		
									8 Battery with treatment Silverline (TR2)		
										0 No one	
											01 Standard

\* Not valid if TA=3

## 2.2 LIST OF ACCESSORIES

Available accessories are indicated below:

Description	Accessory	Standard	Factory fitted	Supplied loose/ activable after delivery
Cu/Al battery with Silver Line anti-corrosion treatment	X		X	
Electronic expansion valve		X	X	
Electronic circulator		X	X	
Water-side safety valve		X	X	
Flow switch (indication of flow presence)		X	X	
Y-filter	X			X
Domestic hot water storage probe / Remote probe	X			X
Three-way diverter valve for hot water production in domestic hot water tank	X			X
Finned battery protection grids	X		X	
Rubber vibratio dampers	X			X
KA - Heat exchanger and crankcase heaters	X		X	
Dry contact on/off remote		X	X	
Dynamic set point		X	X	
Digital input for double set-point		X		X
GI module including: - Plant season signalling - Compressor ON/OFF signalling - General alarm/machine block signalling - Defrosting signalling	X		X	
Three-phase relays for sequence/shortage monitoring		X	X	
Three-phase relay for sequence/shortfall monitoring + min/max voltage detection	X		X	
General circuit breaker	X		X	
Conectivity BMS - protocollo ModBus included (CM)	X			X
Fan silent mode		X	X	
Serial converter USB RS485 (ISK)	X			X
Gateway Modbus RTU (RS485) to BACnet / Lonworks	X			X
Gateway Modbus RTU (RS485) to BACnet / Konnex	X			X
7-touch/HUB (Cloud/App)	X			X
Remote display Touch screen (Hi-T2)	X			X
Remote control (i-Cr)	X			X



## 2.3 DESCRIPTION OF ACCESSORIES

### 2.3.1 Factory-fitted accessories

#### Cu/Al battery with anti-corrosion treatment

finned pack heat exchanger with copper tubes and aluminium fins, treated with a special polyurethane-based paint for corrosion protection. The treatment makes the coil flexible to resist thermal expansion and contraction, mechanically resistant, UV protected and dirt repellent. The treatment guarantees protection of the batteries in practically all environmental conditions: from marine to rural environments, from industrial to urban areas.

For specific cleaning instructions for batteries treated in this way, please refer to the chapter in the user-installer manual entitled "Cleaning of finned batteries treated with the corrosion protection method".

The treatment resists 6000 h according to ASTM B117.

#### Electronic expansion valve

expansion valve, designed for the control and continuous regulation of the amount of refrigerant fed into the evaporator. Changes in thermal load may be followed quickly, so as to achieve optimised consumption.

#### Electronic circulator

standard of the unit, electronically controlled and high efficiency.

#### Water-side safety valve

Valve installed on the hydraulic circuit to control overpressure ola installata sul circuito idraulico per controllare le sovrappressioni – taratura 6 bar

#### Flow switch (flow signal)

device that controls and signals the circulation of water in the plate heat exchanger. This component is of fundamental importance because it shuts down the unit and makes it safe by preventing the formation of ice.

#### Finned coil protection grids

metal mesh to prevent the intrusion of foreign bodies inside the coil and to protect the coil from accidental contact with things or people.

#### KA - Heat exchangers and crankcase heaters

electric resistance located on the front face of the plate heat exchanger, which is activated when the temperature of the water inside the exchanger falls below +4°C. For BT units this value must be set according to the percentage of glycol in the system and the freezing point of the mixture. An electrical resistance is also placed on the base of the unit and is activated when the outside temperature falls below the set level.

#### Dry contact on/off remote

contact on the terminal board that allows the unit to be switched on and off.

#### Dynamic set point

the regulator allows the set-point to be modified by adding a value according to the temperature of the external air probe.

#### GI - Plant management module

allows the management of the following functions:

- Compressor ON/OFF signalling
- General alarm signalling/Machine block signalling

#### Three-phase relay for sequence/absence monitoring

signals the presence of all three phases in the correct sequence.

#### Three-phase relay for sequence/shortage monitoring + min/max voltage detection

signals if all three phases are present in the correct sequence and if all three phase-to-phase voltages are within the set limits. The maximum and minimum voltage thresholds can be set separately.

#### General circuit breaker

Overcurrent circuit breaker applied upstream of electrical components, protects components from failures caused by current peaks.

### 2.3.2 Accessories supplied separately

#### Y-Filter

contains a stainless steel mesh sieve (500 µm filtration) that collects solids in the water. Filtration prevents clogging and/or damage to devices installed downstream of the filter.



#### sanitary storage remote probe\*

temperature probe to be placed inside a thermal flywheel for the instantaneous production of domestic hot water. The DHW storage remote probe thermoregulates the heat pump both during compressor start-up and shutdown.

The probe cannot be connected in the case of DS version

#### System storage remote probe\*

system temperature probe to be positioned inside an external tank. The remote system probe thermoregulates the heat pump only during the compressor start-up phase; shutdown is managed by the probe on the unit's delivery side.

\* Probes cannot be present at the same time

**Three-way diverter valve for hot water production in domestic hot water tank**

Motorised three-way sphere valve DN (1"1/4) Kvs 20,8, complete with servocontrol.

Maximum operating pressure : 10 bar  
 Maximum differential pressure :  $\Delta p = 6$  bar  
 Fluid working temperature :  $0 \div + 100$  °C  
 Usable fluid: Water or compatible liquids with TEFLON and EPDM seals  
 Pressure drop : almost zero

**Rubber antivibration**

are designed to prevent the transmission of vibrations to the structure; they are to be mounted under the unit in special holes.

The optimum recommended load capacities, depending on the size of the machine, are given below



Model i-32V5H Midi	Capacity rubber antivibration [daN/mm]
0121, 0126, 0128, 0132	63

**Digital input for double set point**

input to change the set point.

**BMS connectivity provision - ModBus protocol included (CM)**

accessory allowing connection of the unit to external controllers via serial cable with RS-485 electrical standard and ModBus RTU protocol.

**Fan silent mode**

Digital input that can be activated by an external contact to reduce the sound power level by acting on the ventilation. The mode is particularly suitable during night operation. Below are the decreases in capacity and sound power level when the "fan silent mode" function is active. The reduction refers to the test condition (3) of the technical data tables; the value is determined on the basis of measurements carried out in accordance with UNI EN ISO 9614-2, in compliance with the requirements of Eurovent certification.

Model i-32V5H Midi	Yield reduction factor [-] A7W35	Sound power level reduction [dB(A)]
0121	0,989	-1
0126	0,981	-1
0128	0,978	-1
0132	0,972	-1

**Serial converter USB RS485 (ISK)**

interface device capable of reading and writing control registers via the RS485 standard and converting it to a USB port that can be connected to any supervisory system.

**Gateway Modbus RTU (RS485) to BACnet / Lonworks**

device that enables conversion between Modbus RTU and BACnet/ Lonworks, allowing the unit control to be configured as a normal device in the BACnet / Lonworks network.

**Gateway Modbus RTU (RS485) to BACnet / Konnex**

device that enables conversion between Modbus RTU and BACnet/ Konnex, allowing the unit control to be configured as a normal device in the BACnet/ Konnex network.

**7-touch/HUB (Cloud/App)**

is a compact system consisting of an ultra-thin touch panel, including a temperature control unit and gateway for remote control from a PC (through the "my.maxa.it" portal) or smartphone (through the app that can be downloaded from the "My Maxa" online store). It allows winter and summer climate control.

**Remote display Touch screen (Hi-T2)**

touch screen remote control for centralised management of a chiller/heat pump network, it integrates humidity and temperature sensors for thermo-hygrometric analysis of the environment and management of the double set point for under-floor radiant systems using a dehumidification system.



**Remote control (i-Cr)**

Modbus remote control with negative LCD and capacitive keys. The device is to be used as a remote machine keyboard with local temperature detection, replicating the functionality of the on-board control.



**3. INSTALLATION**

All handling, installation and maintenance operations must be carried out by QUALIFIED PERSONNEL only. Before any operation on the unit, make sure that the power supply is disconnected. The minimum permissible temperature for storing the units is 5°C.

**3.1 UNIT DIMENSIONS, HYDRAULIC CONNECTIONS, WEIGHTS AND CENTRE OF GRAVITY POSITION**

**3.1.1 Net dimensions and with packaging**

Model i-32V5H Midi	Lenght [mm]	Widht [mm]	Height [mm]
0121	1600	680	1315
0126	1600	680	1315
0128	1600	680	1315
0132	1600	680	1315

Model with packaging	Lenght [mm]	Widht [mm]	Height [mm]
0121	1660	700	1412
0126	1660	700	1412
0128	1660	700	1412
0132	1660	700	1412

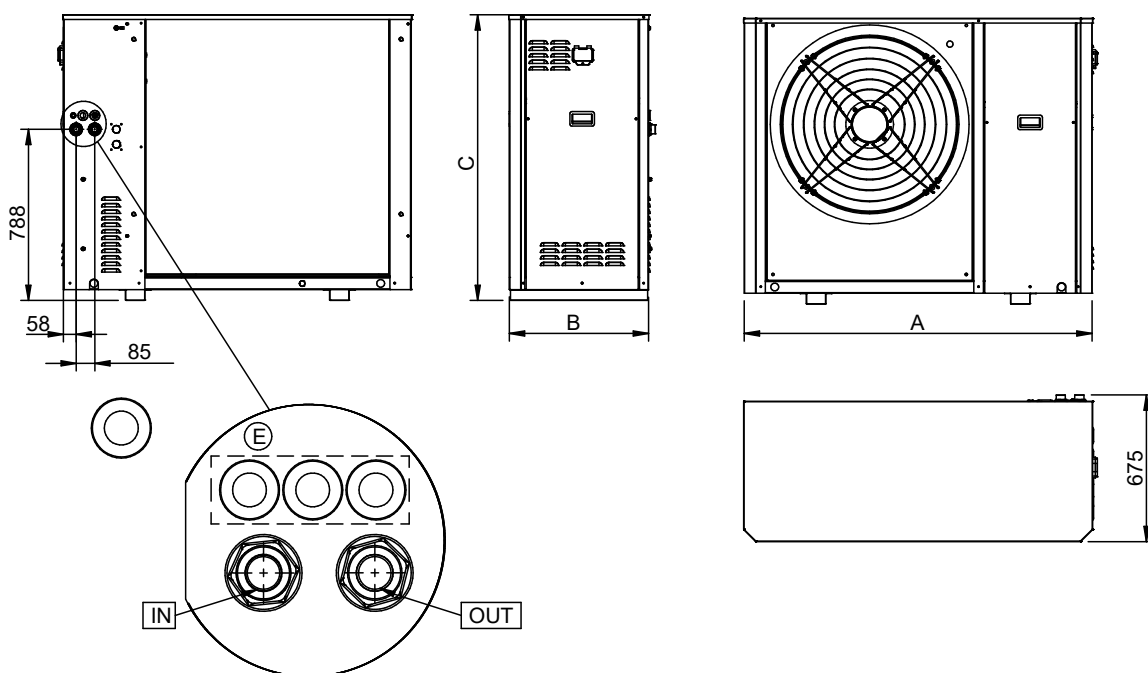

### 3.1.2 Detail of connections and location

Model i-32V5C Midi	Hydraulic connections IN/OUT
0121	1" M
0126	1" M
0128	1"1/4 M
0132	1"1/4 M

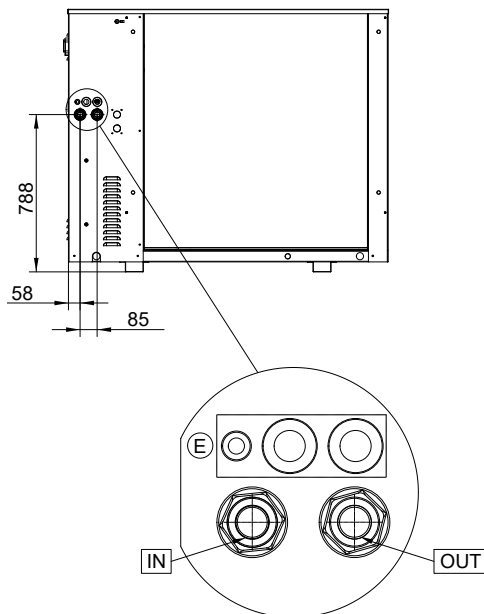

### 3.1.3 Weights

Model i-32V5H Midi	Shipping weight [kg]	Weight in service [kg]
0121	250	240
0126	250	240
0128	265	255
0132	265	255

### 3.1.4 Location of the centre of gravity and vibrations dampers

The position of the centre of gravity of each machine is shown in the tables, with reference to the dimensions shown in the image.

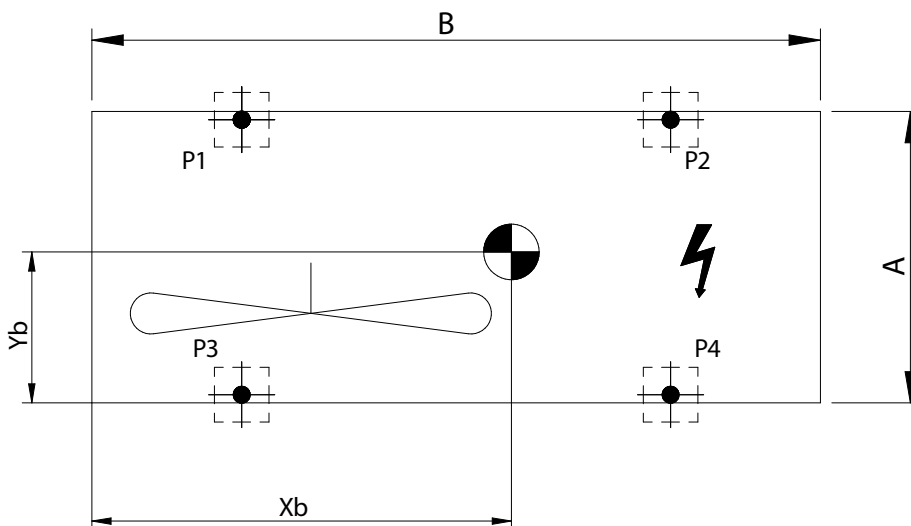

Model i-32V5H Midi	Shipping weight [kg]	Weight in service [kg]	A [mm]	B [mm]	Xb [mm]	Yb [mm]
0121, 0126	250	240	680	1600	949	322
0128, 0132	265	255	680	1600	912	325

The positions provided for the installation of vibration dampers for each type of machine are shown in the pictures below.

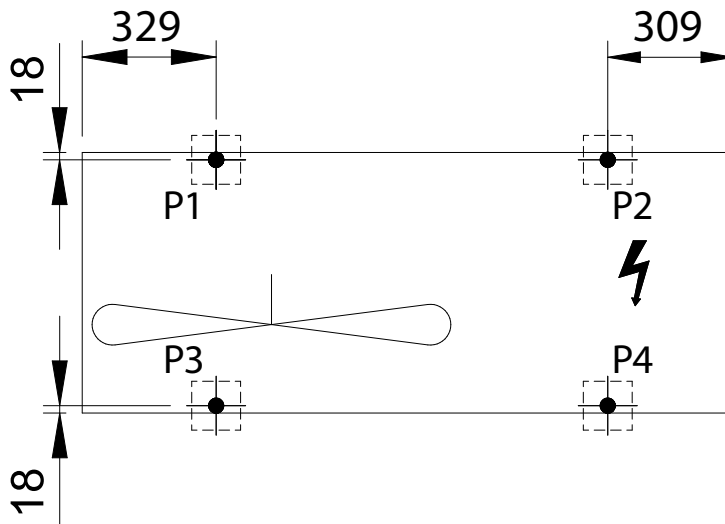

### 3.2 TECHNICAL SERVICE AREAS

All models in the series are designed and constructed for outdoor installation. It is good practice to create a support slab of adequate size for the unit. The units transmit a low level of vibration to the ground: it is nevertheless advisable to place anti-vibration mounts between the base frame and the support surface.

	<p><b>SUSPENDED INSTALLATION IS PROHIBITED</b></p>
	<p>The support surface must have a sufficient capacity to support the weight of the unit, which can be seen on the technical label affixed to the machine and in the specific chapter of this manual. The support surface must not be inclined to ensure correct operation of the unit and to prevent it from tipping over. The installation surface of the unit must not be smooth, to avoid the deposit of water/ice, potential sources of danger.</p>
	<p>The installation site of the unit must be free from foliage, dust, etc., which could block or cover the heat exchange coils. Installation should be avoided in areas subject to stagnant or falling water, for example from gutters. Also avoid locations subject to snow accumulation (such as corners of buildings with sloping roofs). When installing in areas subject to snowfall, mount the unit on a base 20 to 30 cm above the ground to prevent snow from accumulating around the unit.</p>
	<p>It is recommended to ensure sufficient air exchange to dilute the R32 gas in case of accidental leakage, thus avoiding the formation of explosive atmospheres. For this reason, a minimum distance of 1 metre must be maintained from openings or wells, where the gas could accumulate.</p>
	<p>Do not install the unit under any type of cover, such as roofs, canopies, install the unit under cover of anything type as roofs, shelters and similar.</p>

It is very important to avoid recirculation phenomena between suction and delivery, otherwise the performance of the unit will deteriorate or even interrupt normal operation.

In this respect it is absolutely necessary to guarantee the minimum service spaces indicated below.

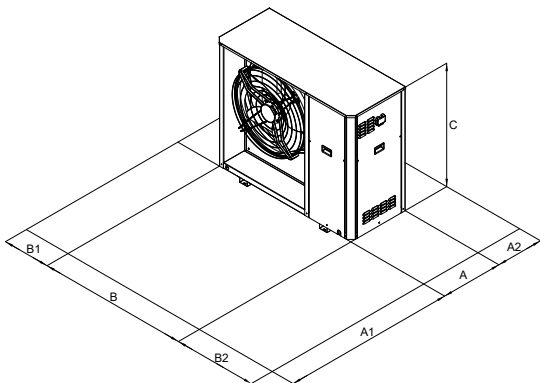

MODEL		A1	A2	B1	B2
i-32V5H Midi 0121, 0126	mm	1500	400	400	700
i-32V5H Midi 0128, 0132	mm	1500	400	400	700



**Obstruction or covering of ventilation openings must be avoided.**



**For installations in locations with strong winds refer to the area classification according to the Beaufort scale. If the value is  $\geq 7$  (strong wind, average wind speed = 13.9-17.1 m/s) it is strictly necessary to keep the fan powered at all times, in order to prevent its involuntary rotation.**

In the case of side-by-side units, the minimum distance  $L_{min}$  between them is 700 mm.

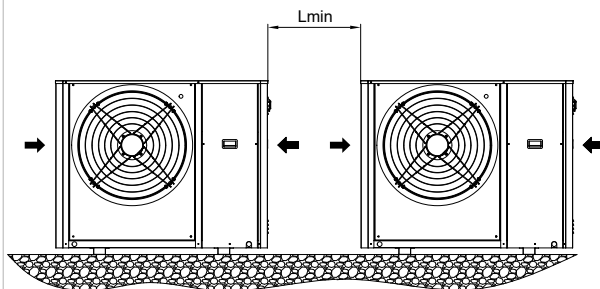

Covering with canopies or positioning near plants or walls should be avoided in order to prevent air circulation.

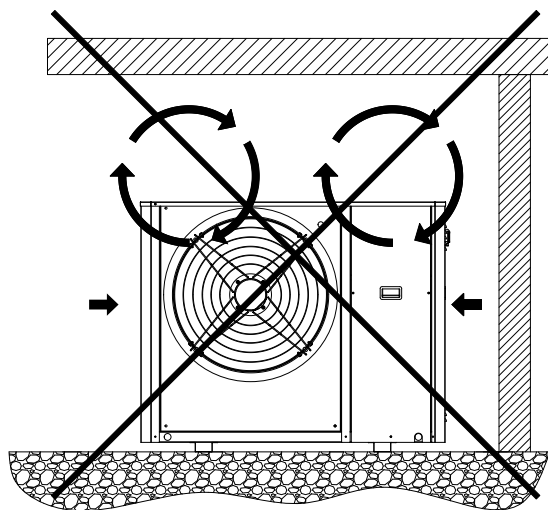

In the case of winds with speeds in excess of 13.9-17.1 m/s (strong winds according to the Beaufort scale), the use of windbreaks is recommended.

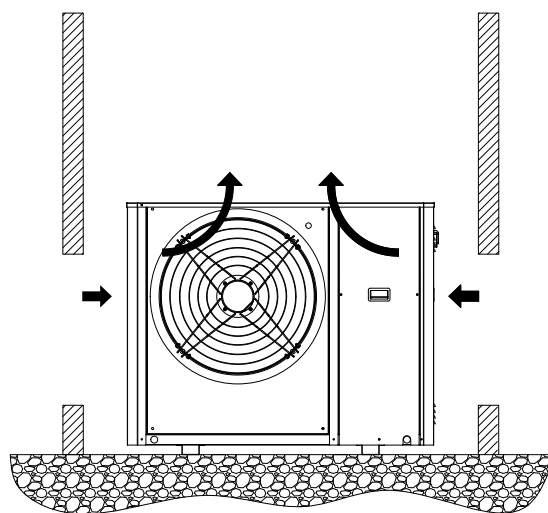

It is always advisable to make an environmental impact assessment based on the power and sound pressure data given in the technical data chapter and the sound emission limits based on the installation area of the unit, with reference to the DPCM of 14/11/1997. An assessment must also be made if the unit is installed in the vicinity of workers, according to D. LGS. 81/2008 Art. 189 and following.

### 3.3 HYDRAULIC CIRCUIT

The hydraulic connections must be made in accordance with national or local regulations; the piping can be made of steel, galvanised steel or PVC. The pipes must be carefully sized according to the nominal water flow rate of the unit and the pressure drops of the hydraulic circuit. All hydraulic connections must be insulated using closed-cell material of adequate thickness. The chiller must be connected to the piping using new, non-reused flexible couplings. It is recommended to install the following components in the hydraulic circuit:

- Thermometers to measure the temperature in the circuit
- Manual gate valves to isolate the chiller from the hydraulic circuit.
- Y-shaped metal filter and a dirt separator (installed on the return pipe from the system) with a metal mesh of no more than 1 mm (obligatory to maintain the validity of the guarantee).
- Charging unit and discharge valve where necessary

	<b>CAUTION:</b> When dimensioning the pipes, make sure that the maximum system-side leakage is not exceeded as shown in the technical data table (see useful head).
	<b>CAUTION:</b> connect the pipes to the connections, always using the key-to-wrench system.
	<b>CAUTION:</b> create a suitable outlet for the safety valve.
	<b>CAUTION:</b> The expansion tank, to be provided externally, must be suitably sized according to the type and volume of fluid, the variation of temperatures and pressures in the system.
	<b>CAUTION:</b> The return line from the system must be at the "WATER INPUT" label, otherwise the evaporator could freeze.
	<b>CAUTION:</b> It is obligatory to install a metal filter (with a mesh size of no more than 1 mm) and a dirt separator on the return pipe from the installation labelled "WATER INPUT". If the flow switch is tampered with or altered, or if the metal filter and dirt separator are not present on the installation, the warranty will be immediately void. The filter and the dirt separator must be kept clean, so make sure they are still clean after the unit is installed and check them periodically.
	All units leave the factory with a flow switch (factory installed). If the flow switch is tampered with or removed, or if the water filter and deflector are not present in the unit, the guarantee will be invalid. Refer to the wiring diagram enclosed with the unit for the connection of the flow switch. Never connect the flow switch connections in the terminal block.
	The heating system and safety valves must comply with the requirements of EN 12828

### 3.3.1 System water specifications

To ensure that the unit functions properly, the water must be adequately filtered (see the beginning of this section) and the quantity of dissolved substances must be minimal. The maximum permitted values are listed below.

MAXIMUM PERMITTED CHEMICAL AND PHYSICAL CHARACTERISTICS OF THE SYSTEM WATER	
PH	7,5 - 9
Electrical conductivity	100 - 500 $\mu$ S/cm
Total hardness	4,5 – 8,5 dH
Temperature	< 65°C
Oxygen content	< 0,1 ppm
Max. quantity glycol	40 %
Phosphates (PO4)	< 2ppm
Manganese (Mn)	< 0,05 ppm
Iron (Fe)	< 0,3 ppm
Alkalinity (HCO3)	70 – 300 ppm
Chlorine ions (Cl-)	< 50 ppm
Sulphate ions (SO4)	< 50 ppm
Sulphide ion (S)	No one
Ammonium ions (NH4)	No one
Silica (SiO2)	< 30 ppm

### 3.3.2 Typical hydraulic scheme

The following is a recommended connection diagram

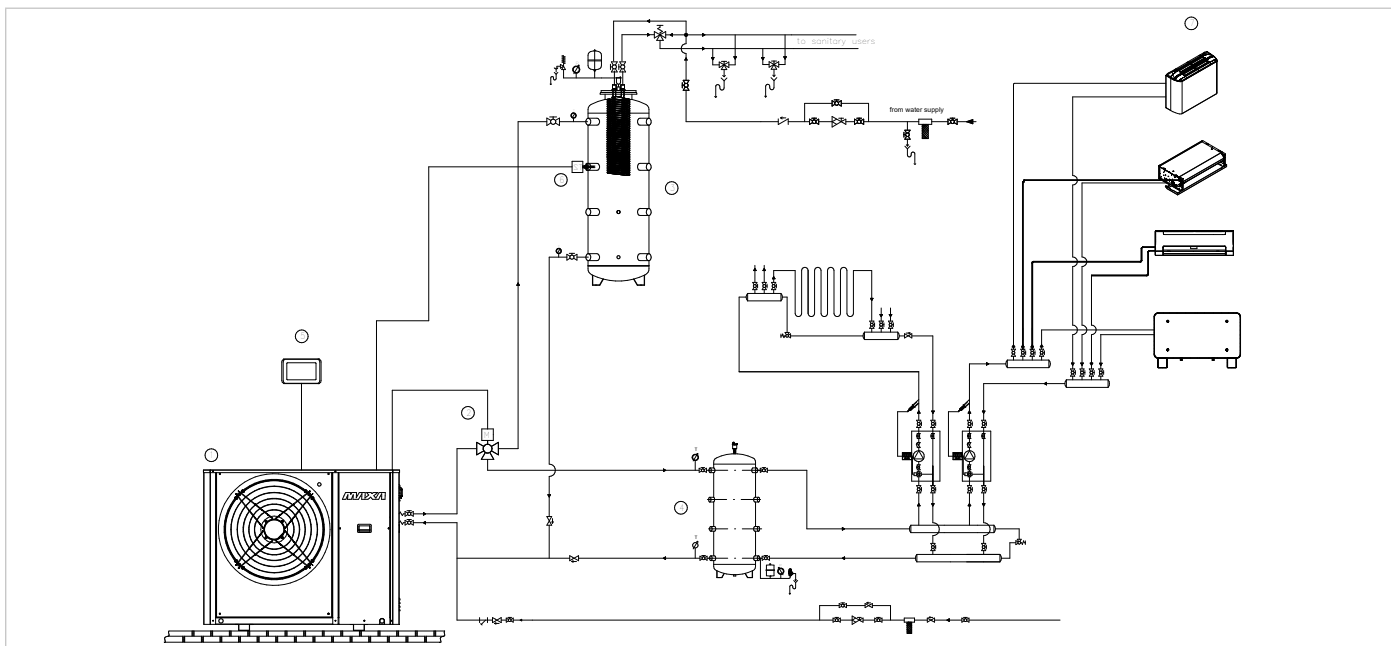

LEGEND			
1	i-32V5H MIDI -HEAT PUMP	5	Hi-T2 REMOTE CONTROLLER
2	VDIS3 - DIVERTER VALVE	6	SAS - SANITARY PROBE
3	CADDY - WATER STORAGE WITH DOMESTIC HOT WATER EXCHANGER	7	FANCOIL TERMINALS
4	PUFFROLLER - TECHNICAL WATER STORAGE		



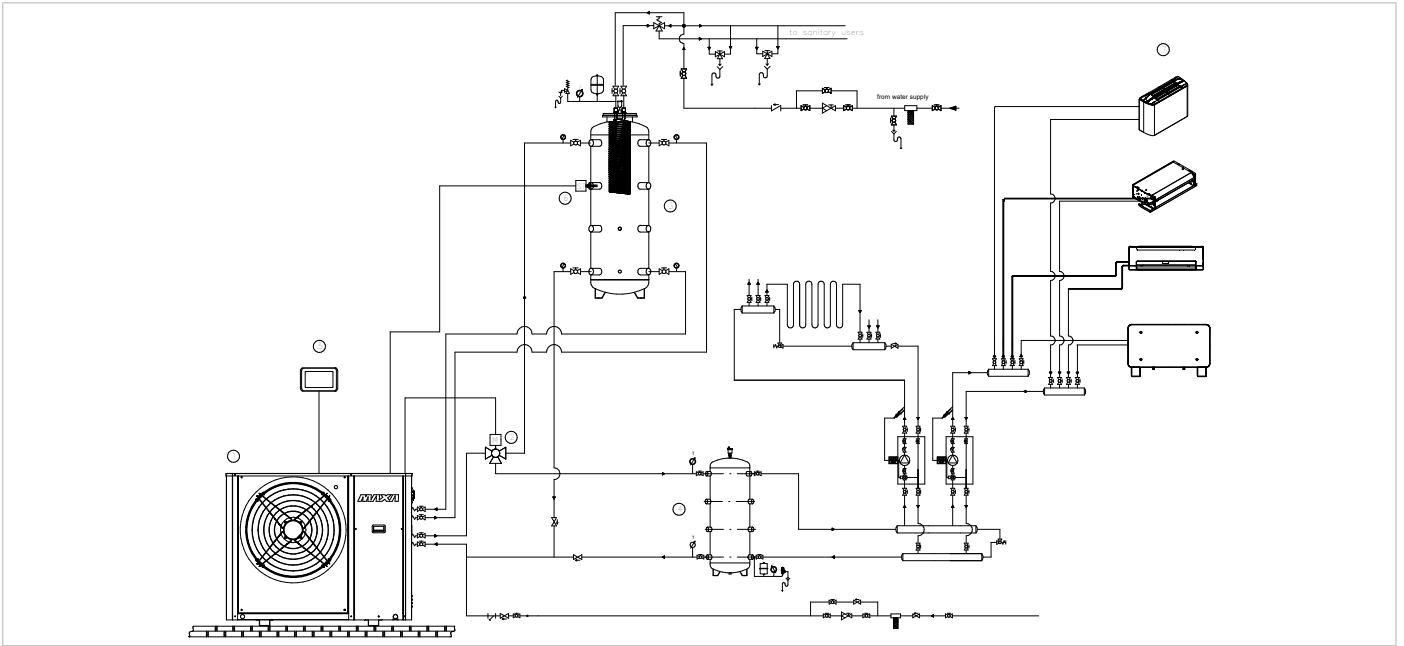

**LEGEND**

1	i-32V5H-DS MIDI - HEAT PUMP WITH DESUPERHEATER	5	Hi-T2 REMOTE CONTROLLER
2	VDIS3 - DIVERTER VALVE	6	SAS - SANITARY PROBE
3	CADDY - WATER STORAGE WITH DOMESTIC HOT WATER EXCHANGER	7	FANCOIL TERMINALS
4	PUFFROLLER - TECHNICAL WATER STORAGE		

### 3.3.3 Hydraulic diagram inside the unit

The hydraulic diagram for connection to the unit is shown below

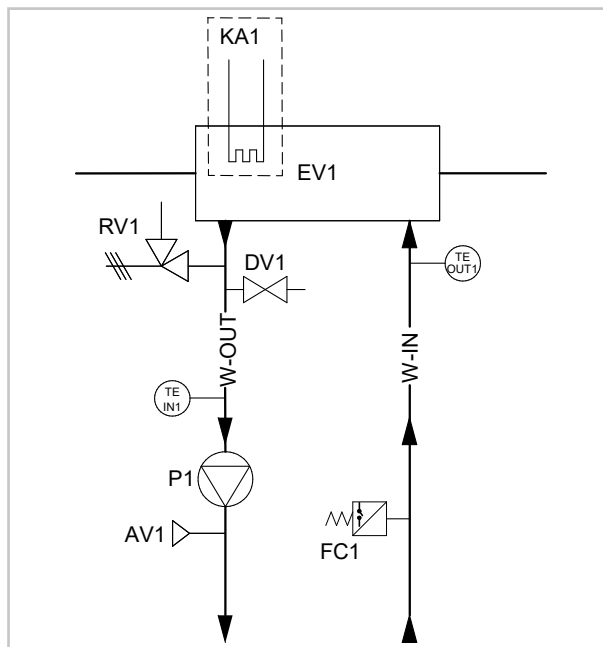

LEGEND					
EV	1	PLATE HEAT EXCHANGER	W-IN		WATER INLET
DV	1	DRAIN TAP	W-OUT		WATER OUTLET
RV	1	SAFETY VALVE	P	1	ELECTRONIC CIRCULATOR
TE IN	1	WATER INLET TEMPERATURE PROBE	AV	1	AUTOMATIC AIR VENT VALVE
TE OUT	1	USER OUTLET WATER TEMPERATURE PROBE	FC	1	FLOW SWITCH
---	Accessory installed on board				

In any case, each unit includes a safety valve with 6 bar opening pressure.



**CAUTION:** It is recommended to connect the safety valve vent to a suitable conveyor/discharge. Otherwise, the discharged water could stagnate around the machine and become a danger due to slipping/falling.

### 3.3.4 Minimum water content and hydraulic circuit volumes

The table shows the minimum recommended plant water content for units. The volume of the hydraulic circuit is also indicated. If this volume is less than the recommended minimum water content, it must be ensured that the pipes connecting to the unit have sufficient capacity to compensate for this difference. The additional volume required is shown in the table.

Model i-32V5H Midi	0121	0126	0128	0132
Minimum system water content [l]	110	110	110	110
Hydraulic circuit volume [l]	2,4	2,4	3,4	3,4

### 3.3.5 Condensate drainage system

As the pipes are well insulated, the production of condensation is minimal and does not lead to the accumulation of water inside the refrigeration compartment. All heat pumps are equipped with a hole in the basement for draining condensation, which is abundant especially in the post-defrost phase.

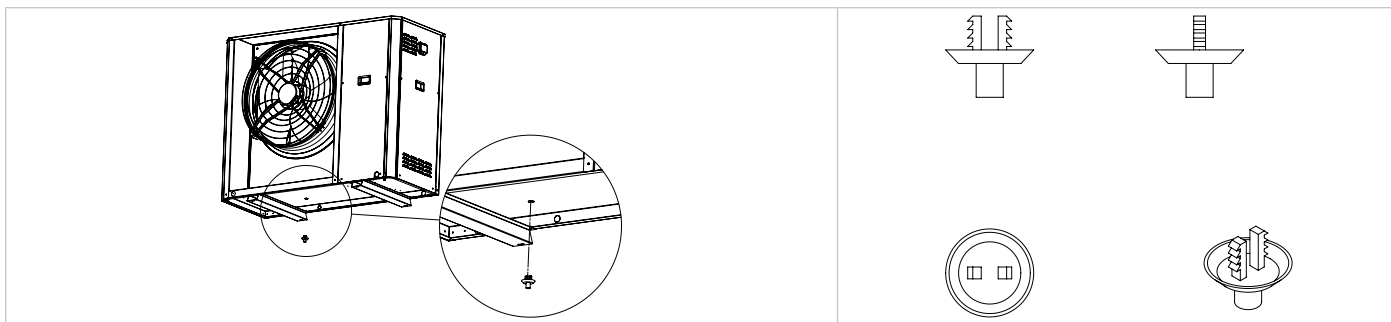

FOR HEAT PUMP UNITS, IN PARTICULARLY RIGID CLIMATES, THE INSTALLATION OF THE KA ACCESSORY IS RECOMMENDED, WHICH PREVENTS THE FORMATION OF ICE ON THE BASEMENT.



**CAUTION:** for heat pump units, in the event that the prepared ducting system is not used, a limited amount of water (possible ice in the winter period) from the condensate drainage system may be deposited in the vicinity of the unit, with consequent danger of slipping/falling.

### 3.3.6 System charging/discharging



**CAUTION:** supervise all charging/reintegration operations.

**CAUTION:** Before charging/reintegration the system, disconnect the power supply to the units.

**CAUTION:** The charging/reintegration of the system must always take place under controlled pressure (1÷3 bar). Make sure that a pressure reducer and a safety valve have been installed on the charging/reintegration line.

**CAUTION:** The water in the filling/reintegration line must be pre-filtered from impurities and suspended particles. Ensure that a removable cartridge filter and a dirt separator are installed.

**CAUTION:** periodically check and vent the air that accumulates in the system

**CAUTION:** provide an automatic air release valve at the highest point of the installation

If it is necessary to top up the system or adjust the glycol content, the service tap can be used. Unscrew the cap of the service tap (A) and connect a 14 or 12 mm pipe (internal diameter measurements - check the tap model installed on your unit) to the hose connector connected to the water mains, then fill the system by unscrewing the ring nut (B). After this operation, tighten the ring nut (B) again and screw the cap (A) back on. In any case, it is advisable to use an external tap to fill the system.

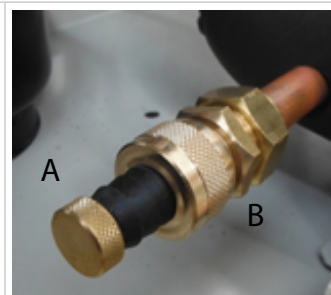

If the unit must be completely drained, first close the manual inlet and outlet shutters (not supplied) and then disconnect the pipes externally arranged on the water inlet and outlet in order to drain the liquid contained in the unit (to make the operation easier, it is advisable to install two external drain cocks on the water inlet and outlet interposed between the unit and the manual shutters).

### 3.3.7 Air vent valve

È possibile lasciare la valvola in posizione chiusa chiudendo il tappino sullo scarico; allentando il tappino la valvola rimane in posizione aperta e lo scarico dell'aria avviene in modo automatico. The unit is equipped with an air vent valve that automatically eliminates the air accumulated inside the circuit, avoiding: undesirable effects such as premature corrosion and wear, lower efficiency and reduced exchange yield. The device also has a safety function in that, in the event of a break in the exchanger, it allows the refrigerant gas to escape into the external air, preventing it from being transported to the internal terminals. It is possible to leave the valve in the closed position by closing the cap on the outlet; by loosening the cap the valve remains in the open position and the air is discharged automatically.



If you notice a water leak, you must replace the component by unscrewing it with a spanner, as shown in the image below.



## 4. TECHNICAL DATA

### 4.1 HEAT PUMP DATA SHEET

TECHNICAL CHARACTERISTICS		Unit	i-32V5H MIDI			
			0121	0126	0128	0132
Cooling	Cooling capacity (1) min/nom/max	kW	6,9 / 17,7 / 18,0*	7,8 / 18,7 / 22,7*	9,0 / 24,2 / 25,0*	10,1 / 26,0 / 27,5*
	Power input (1)	kW	5,87	6,19	7,98	8,65
	E.E.R. (1)	W/W	3,02	3,02	3,03	3,01
	Cooling capacity (2) min/nom/max	kW	11,1 / 22,0 / 25,1*	12,5 / 26,2 / 27,7*	13,3 / 29,0 / 30,8*	14,8 / 31,4 / 32,7*
	Power input (2)	kW	4,50	5,56	6,36	7,08
	E.E.R. (2)	W/W	4,89	4,71	4,56	4,44
	SEER (5)	W/W	4,35	4,46	4,69	4,73
	Water flow (1)	L/s	0,8	0,9	1,2	1,2
	Pressure drops exchanger side (1)	kPa	32,5	34,5	31,2	34,2
Heating	Heating capacity (3) min/nom/max	kW	8,8 / 21,3 / 25,3*	9,5 / 26,0 / 27,3*	11,1 / 28,0 / 31,4*	11,9 / 32,1 / 33,9*
	Power input (3)	kW	4,92	6,44	6,35	7,84
	C.O.P. (3)	W/W	4,33	4,04	4,41	4,09
	Heating capacity(4) min/nom/max	kW	8,6 / 21,3 / 25,2*	9,4 / 25,8 / 27,6*	10,5 / 28,3 / 30,7*	12,1 / 32,7 / 34,5*
	Power input (4)	kW	6,58	7,86	8,21	9,90
	C.O.P. (4)	W/W	3,24	3,28	3,45	3,30
	SCOP (6)	W/W	4,20	3,95	4,29	4,02
	Water flow (4)	L/s	1,0	1,2	1,4	1,6
	Pressure drops exchanger side (4)	kPa	37,9	53,1	41,4	50,6
	Energy efficiency water 35°C / 55°C	Classe	A++/A+	A++/A+	A++/A++	A++/A+
Compressor	Type		Twin Rotary DC Inverter			
	Number of compressors		1	1	1	1
	Cooling oil (type)		PVE VG50	PVE VG50	PVE VG50	PVE VG50
	Cooling oil (quantity)	L	1,5	1,5	1,5	1,5
	Refrigerant circuits		1	1	1	1
Chiller	Type		R32	R32	R32	R32
	Refrigerant quantity (7)	kg	4,3	4,3	5,1	5,1
	Refrigerant quantity in ton. of CO2 equivalent (7)	ton	2,90	2,90	3,44	3,44
	Design pressure (high/low) mod. heat pump	bar	42,8/1,3	42,8/1,3	42,8/1,3	42,8/1,3
	Design pressure (high/low) mod. chiller	bar	42,8/3,5	42,8/3,5	42,8/3,5	42,8/3,5
Outdoor area fans	Type		Motor DC Brushless			
	Number		1	1	1	2
	Nominal power (1)	kW	0,26	0,26	0,50	0,62
	Maximum power input	kW	1,25	1,25	0,83	0,83
	Maximum current input	A	2,0	2,0	1,45	1,45
	Nominal air flow rate (1)	m3/h	10769	10847	12209	13202
Internal ex-changer	Type of internal exchanger		Plate			
	N° internal exchanger		1	1	1	1
	Water content	L	1,7	1,7	2,1	2,1
Hydraulic circuit	Useful prevalence (1)	kPa	90,0	86,5	81,4	74,7
	Water content of the hydronic circuit	L	2,4	2,4	3,4	3,4
	Maximum pressure hydronic kit (safety valve calibration)	bar	6	6	6	6
	Hydraulic connections	inch	1"M	1"M	1"1/4 M	1"1/4 M
	Minimum water capacity (8)	L	110	110	110	110
	Maximum circulator power	kW	0,31	0,31	0,31	0,31
	Max. circulator current input	A	1,37	1,37	1,37	1,37
	Circulator Energy Efficiency Index (EEI)		≤ 0,23	≤ 0,23	≤ 0,23	≤ 0,23
Sound emissions	Sound power Lw (9)	dB(A)	71	73	75	77
	Power supply		400V/3P+N+T/50Hz			
Electrical data	Maximum power input	kW	15,0	15,0	17,6	17,6
	Maximum current input	A	21,7	21,7	25,4	25,4
	Maximum power input with antifreeze kit	kW	15,2	15,2	17,8	17,8
	Maximum current input with antifreeze kit	A	22,0	22,0	25,8	25,8

Performance referring to the following conditions, according to standard 14511:2018:

(1) Cooling: outdoor air temperature 35°C; in/out water temperature 12/7°C.

- (2) Cooling: outdoor air temperature 35°C; in/out water temperature 23/18°C.
- (3) Heating: outdoor air temperature 7°C b.s. 6°C b.u.; in/out water temperature 30/35°C.
- (4) Heating: outdoor air temperature 7°C b.s. 6°C b.u.; in/out water temperature 40/45°C.
- (5) Cooling: in/out water temperature 7/12°C.
- (6) Heating: medium climatic conditions; T<sub>biv</sub>=-7°C; in/out water temperature 30/35°C.
- (7) Indicative data subject to changes. For the correct value, always refer to the technical label on the unit.
- (8) Calculated for a decrease in system water temperature of 10°C with a defrost cycle lasting 6 minutes.
- (9) Sound power level: heating mode condition (3); value determined on the basis of measurements made in accordance with UNI EN ISO 9614-2, in compliance with the requirements of Eurovent certification.
- (\*) activating the maximum Hz function

**N.B. i dati prestazionali riportati sono indicativi e possono essere soggetti a variazione. Inoltre le rese dichiarate ai punti (1), (2), (3) e (4) sono da intendersi riferite alla potenza istantanea secondo UNI EN 14511. Il dato dichiarato al punto (5) e (6) è determinato secondo la UNI EN 14825.**

## 4.2 DATA SHEET UNIT WITH DESUPERHEATER

The performance with desuperheater is shown, under conditions (1) of the technical data table, for water outlet temperatures of 45°C and 55°C from the desuperheater.

Model i-32V5H Midi	T <sub>out DS</sub> =45°C					T <sub>out DS</sub> =55°C				
	Cooling capacity [kW]	Power input [kW]	EER [W/W]	Heatig capacity DS [kW]	Pressure drop DS [kPa]	Cooling capacity [kW]	Power input [kW]	EER [W/W]	Heating capacity DS [kW]	Pressure drop DS [kPa]
0121	17,8	5,8	3,07	6,1	14,14	17,7	5,9	3,03	4,6	8,55
0126	19,0	6,1	3,12	6,6	16,62	18,9	6,1	3,08	5,1	10,20
0128	24,4	7,9	3,10	8,5	20,51	24,3	7,9	3,06	6,5	12,60
0132	26,3	8,5	3,08	9,1	23,43	26,1	8,6	3,04	7,1	14,60

The useful heads of the circulator associated with the desuperheater are shown below. The operating points shown in the previous table are also represented.

Models i-32V5H Midi 0121, 0126		Models i-32V5H Midi 0128, 0132	
Water flow rate DS [m³/h]	Useful head of circulator associated to DS [kPa]	Water flow rate DS [m³/h]	Useful head of circulator associated to DS [kPa]
0,4	82,7	0,4	83,1
0,6	79,4	0,6	80,5
0,8	74,2	0,8	76,1
1,0	67,2	1,0	70,0
1,2	58,7	1,2	62,5
1,4	48,8	1,4	53,9
1,6	37,6	1,6	44,2
1,8	25,5	1,8	33,5
2,0	12,3	2,0	22,2

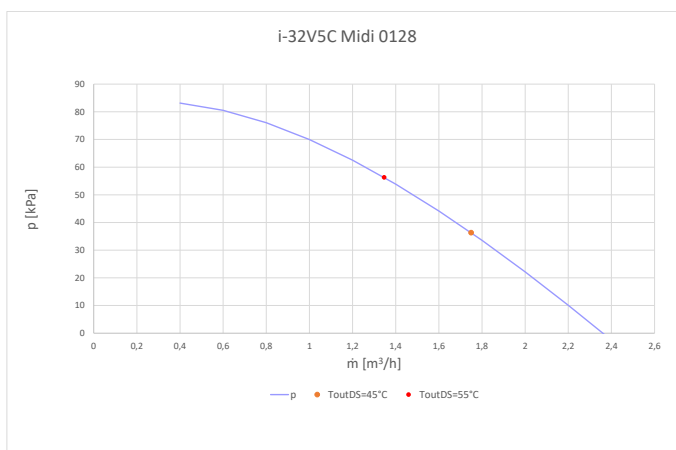
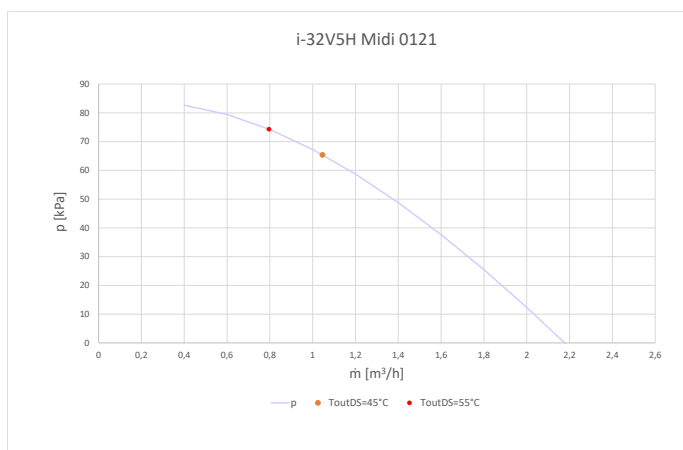

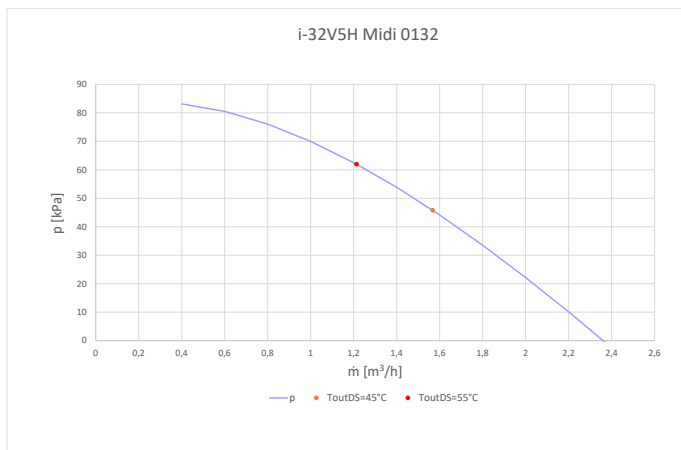
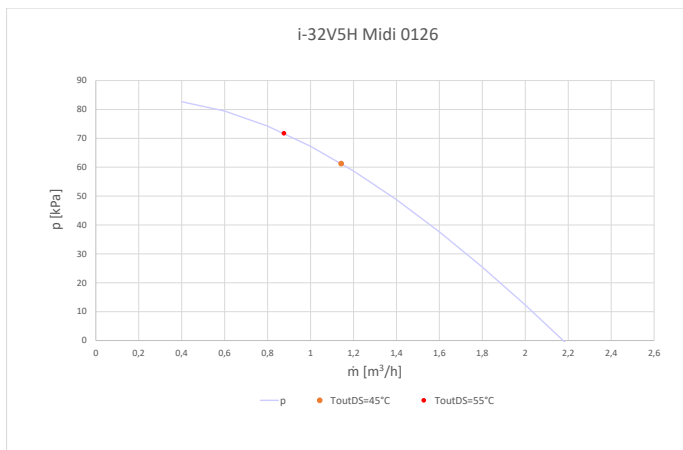

p [kPa]	useful prevalence
$\dot{m}$ [m <sup>3</sup> /h]	water flow rate

### 4.3 UNIT AND AUXILIARY ELECTRICAL DATA

Unit power supply	V/~/Hz	400/3PH+PE/50
On-board control circuit	V/~/Hz	12/1/50
Remote control circuit	V/~/Hz	12/1/50
Fan power supply	V/~/Hz	400/3PH+PE/50

**NOTE:** Electrical data is subject to change due to updating. It is therefore always necessary to refer to the technical characteristics label attached to the unit.

## 5. CORRECTIVE FACTORS

### 5.1 CORRECTION FACTORS FOR USE OF WATER-GLYCOLE MIXTURE

The correction factors for water flow rate and pressure drop must be applied to the values obtained without the use of glycol. The correction factor for water flow rate shall be calculated to maintain the same temperature difference as would be obtained without the use of glycol. The pressure drop correction factor is applied to the water flow rate value corrected by the water flow rate correction factor.

Percentage of glycol	Freezing point [°C]	yeld corrector factor	Absorbed power correction factor	Water flow correction factor	Pressure drop correction factor
10%	-3,2	0,985	1	1,02	1,08
20%	-7,8	0,98	0,99	1,05	1,12
30%	-14,1	0,97	0,98	1,10	1,22
40%	-22,3	0,965	0,97	1,14	1,25
50%	-33,8	0,955	0,965	1,2	1,33

### 5.2 SCALING CORRECTION FACTOR

The correction factors due to contamination of the internal gas/water exchanger are shown below.

m <sup>2</sup> °C/kW	power output correction factor	power input correction factor
0,44 x 10 <sup>-1</sup>	1,00	1,00
0,88 x 10 <sup>-1</sup>	0,99	1,00
1,76 x 10 <sup>-1</sup>	0,98	1,00

### 5.3 CALIBRATIONS AND PROTECTIONS CONTROL

Description	Value
High pressure switch	42,8 bar
High pressure alarm	41,5 bar
Low pressure alarm (cooling/heating)	3,5 bar / 1,3 bar
Maximum number of restarts/hour after high/low pressure alarm (manual reset)	3
Protezione antigelo (versione standard/versione BT)	3°C / -10°C

Description	Value
hydraulic circuit safety valve	6 bar

\*Check that the antifreeze mixture concentration is suitable for the freezing temperature.

## 5.4 CORRECTION FACTORS DEPENDING ON ALTITUDE

The correction factors for performance as a function of altitude are calculated for cooling under the conditions (1) and for heating under the conditions (3) in the above technical data tables and are given for altitudes of 500, 1000, 1500 and 2000 m.

Altitude [m]	500	1000	1500	2000
correction factor heat output	0,9964	0,9941	0,9888	0,9869
Correction factor power input in heating mode	0,9931	0,9841	0,9853	0,9755
Correction factor cooling capacity	0,9888	0,9762	0,9618	0,9466
Correction factor power input in cooling mode	1,0106	1,0235	1,0386	1,0560

## 6. HYDRONIC GROUP DATA DATI DEL GRUPPO IDRONICO

### 6.1 USEFUL HEAD

Di seguito si riportano le curve caratteristiche prevalenza-portata al netto delle perdite di carico del kit idronico. On each curve the optimal working point corresponding to condition (1) of the technical data table is highlighted.

The system must be designed in such a way as to guarantee the nominal flow rate relative to the working points shown below.

Flow rate m [l/s]	Useful head p models 0121, 0126 [kPa]	Useful head p model 0128, 0132 [kPa]
0,5	107,4	111,2
0,6	103,5	108,7
0,7	98,6	105,5
0,8	92,7	101,5
0,9	85,8	96,7
1,0	78,0	91,2
1,1	69,2	84,9
1,2	59,4	77,7
1,3	48,6	69,8
1,4	36,6	61,2
1,5	23,5	51,8
1,6	9,4	41,6

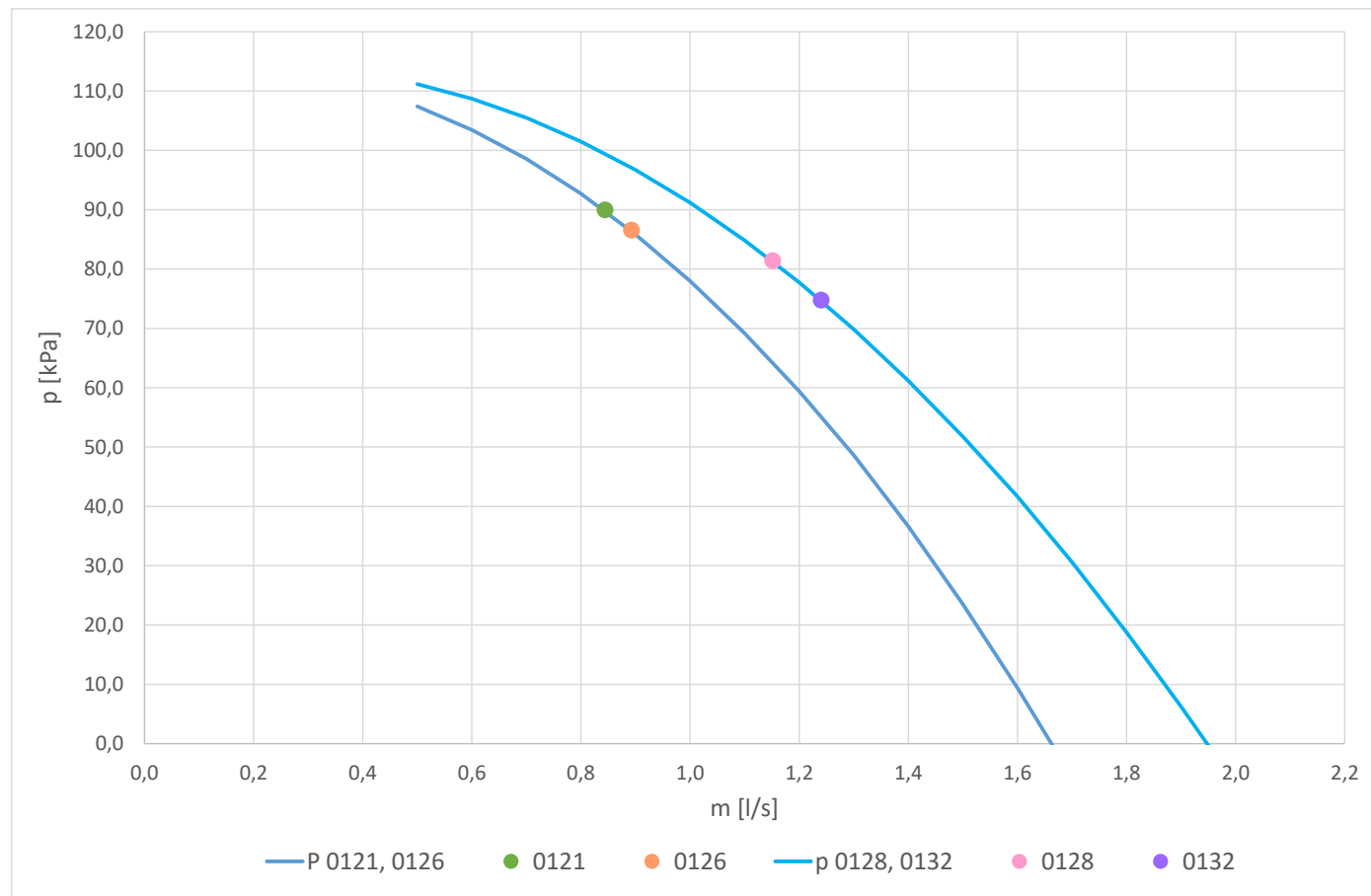

### 6.2 PRESSURE DROP Y-FILTER ACCESSORIES 3-WAY VALVE

Flow rate [l/s]	Pressure drop Y-filter models 0121, 0126 [kPa]	Pressure drop Y-filter models 0128, 0132 [kPa]
0,5	1,92	1,44
0,6	2,76	2,07
0,7	3,76	2,82
0,8	4,91	3,69



Flow rate [l/s]	Pressure drop Y-filter models 0121, 0126 [kPa]	Pressure drop Y-filter models 0128, 0132 [kPa]
0,9	6,21	4,67
1,0	7,67	5,76
1,1	9,28	6,97
1,2	11,04	8,29
1,3	12,96	9,73
1,4	15,03	11,29
1,5	17,25	12,96
1,6	19,63	14,75
1,7	22,16	16,65
1,8	24,85	18,66

Flow rate [l/s]	Three-way pressure drops models 0121, 0126 [kPa]	Three-way pressure drops models 0128, 0132 [kPa]
0,5	0,75	0,75
0,6	1,08	1,08
0,7	1,47	1,47
0,8	1,92	1,92
0,9	2,43	2,43
1,0	3,00	3,00
1,1	3,62	3,62
1,2	4,31	4,31
1,3	5,06	5,06
1,4	5,87	5,87
1,5	6,74	6,74
1,6	7,67	7,67
1,7	8,66	8,66
1,8	9,71	9,71

### 6.3 CIRCULATOR/PUMP CURVES

We report the range of useful heads that the machine guarantees during circulator modulation.

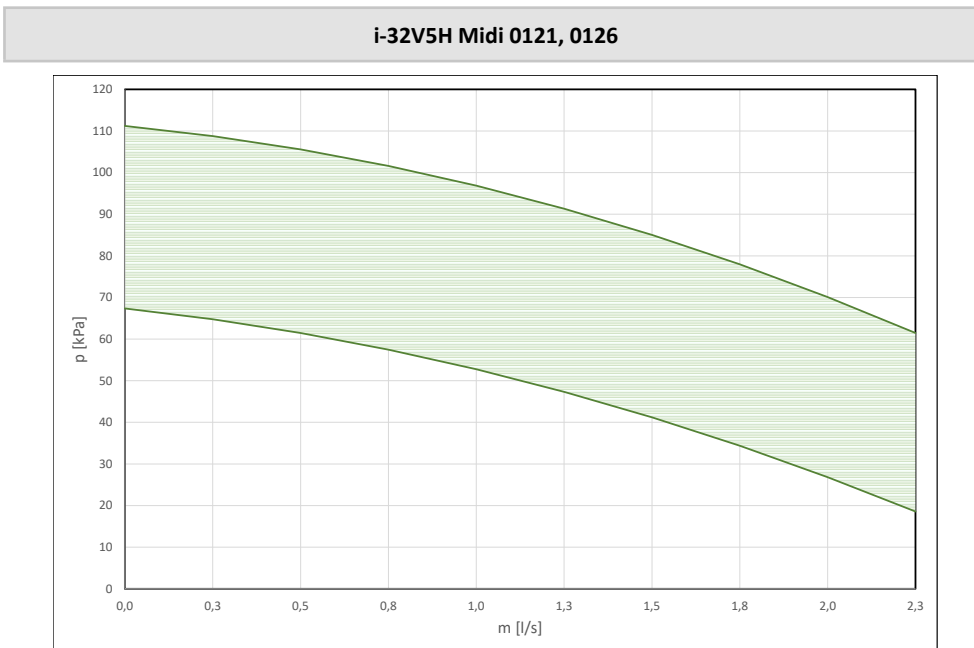

**i-32V5H Midi 0128, 0132**

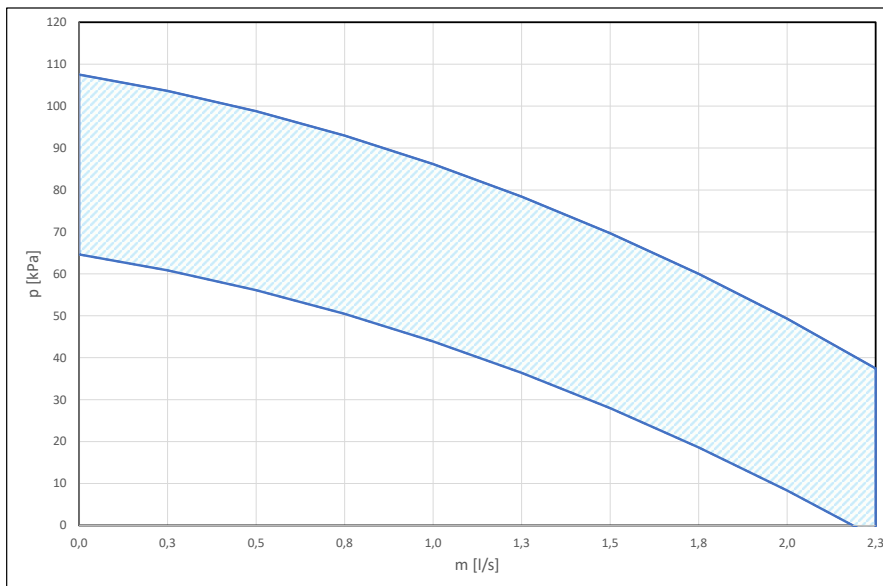

## 7. SOUND EMISSIONS

The sound levels refer to a fully loaded units at standard nominal conditions in accordance with EU Regulation 813/2013. The tolerance on the value of the total sound power level is 2 dB(A). The value is determined in accordance with EN 12102-1:2017, used in conjunction with UNI EN ISO 9614-2 which describes how to test with the intensimetric method.

The sound pressure values are calculated from the sound power level using ISO 3744:2010, considering units operating in the open area.

### 7.1 POWER AND SOUND PRESSURE STANDARD

Model i-32V5H MIDI	Octave band sound power level							Sound power level Lw(A) [dB(A)]	Sound pressure level at 1m [dB(A)]	Sound pressure level at 10m [dB(A)]
	63 Hz	125 Hz	250 Hz	500 Hz	1000 Hz	2000 Hz	4000 Hz			
0121	47,3	65,5	60,7	61,4	65,3	65,2	58,9	71	55,1	39,5
0126	53,7	57,7	62,4	62,6	68,9	66,2	62,4	73	57,1	41,5
0128	49,5	62,5	65,2	69,4	66,7	71,9	59,3	75	59,1	43,5
0132	46,6	63,1	66,5	65,0	67,3	75,9	62,0	77	61,1	45,5

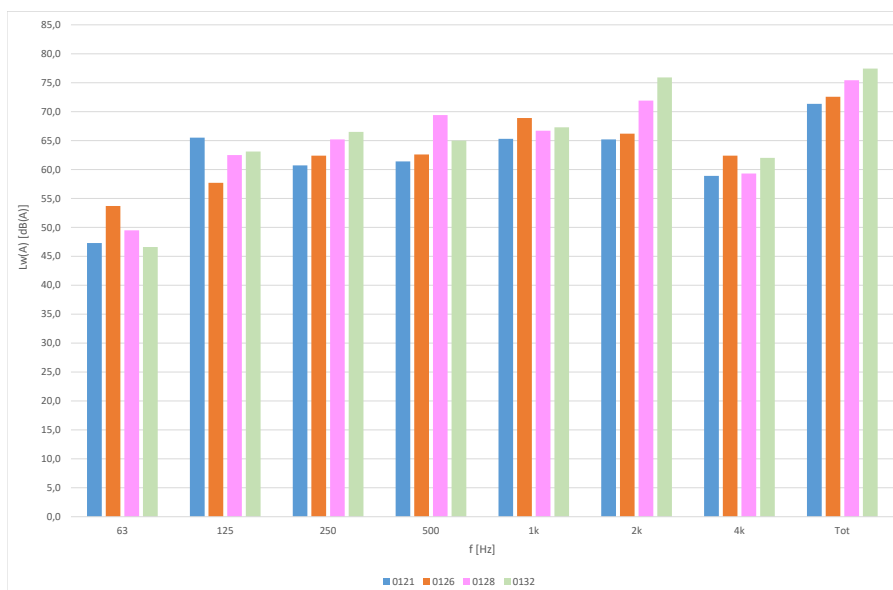

## 8. OPERATING LIMITS

### 8.1 WATER FLOW RATE AT THE EVAPORATOR

The nominal water flow rate refers to a temperature difference between the inlet and outlet of the evaporator of 5°C. The maximum permissible flow rate is the one with a temperature difference of 3°C and the minimum is the one with a temperature difference of 8°C at nominal conditions as indicated in the data sheet



**Insufficient water flow rate can cause evaporation temperatures too low with the intervention of the safety devices and the stopping of the unit and, in some limit cases, with the formation of ice in the evaporator and consequent serious failures of the refrigeration circuit.**

For greater precision we enclose a table showing the minimum flow rates to be ensured to the plate heat exchanger in order to guarantee its correct operation (please note: the water flow switch prevents the anti-freeze probe from tripping due to lack of flow, but does not guarantee the correct operation of the unit)

Model i-32V5H Midi	0121	0126	0128	0132
Minimum water flow rate to be guaranteed in chiller mode (condition (1) data sheet) [l/s]	0,529	0,558	0,723	0,776
Maximum water flow rate to be guaranteed in chiller mode (condition (1) data sheet) [l/s]	1,41	1,49	1,93	2,07
Intervention flow rate status – flow switch decreasing* [l/s]	0,445	0,445	0,528	0,528
Intervention flow rate status – flow switch increasing* [l/s]	0,477	0,477	0,588	0,588

\* When the flow rate falls below the indicated limit (flow switch intervention flow rate - decreasing flow) the flow switch signals an alarm, which can only be reset when the flow switch intervention low rate - increasing flow - is reached.

### 8.2 CHILLER WATER PRODUCTION (SUMMER OPERATION)

The minimum allowed evaporator outlet temperature is 5°C for units with standard configuration. In case of units with BT configuration (low temperature) the limit drops to -8°C. In this the use of glycol water is necessary. The maximum temperature that can be maintained at steady state at the evaporator outlet is 22°C.

### 8.3 HOT WATER PRODUCTION (WINTER OPERATION)

Once the system is running the water inlet temperature must not fall below 20°C: lower value not due to transient or start-up phases, can cause system faults with the possibility of compressor failure. The maximum water outlet temperature must not exceed 60°C. Temperature higher than those indicated, especially in conjunction with water flow rates, could result in malfunctioning of the unit, or in the most critical cases safety devices could be triggered.

### 8.4 AMBIENT AIR TEMPERATURE AND SUMMARY TABLE

The unit are designed and built to operate in summer mode, with condensation control, with outdoor air temperature between -15°C and 48°C. In heat pump operation, the allowed range of outdoor air temperature varies from -20°C to 35°C depending on the outlet water temperature, as shown in the table below.

Water chiller mode		
Ambient temperature	Minimum -15°C	Maximum 48°C
Water outlet temperature standard version	Minimum 5°C	Maximum 22°C
Water outlet temperature BT version	Minimum -8°C	Maximum 22°C
Heat pump mode		
Ambient temperature	Minimum -20°C	Maximum 35°C
Water outlet temperature	Minimum 25°C	Maximum 60°C
Domestic hot water heat pump mode		
Ambient temperature with water at 44°C maximum	Minimum -20°C	Maximum 40°C
Ambient temperature with water at 60°C maximum	Minimum -7°C	Maximum 26°C
Water outlet temperature	Minimum 25°C	Maximum 60°C

Below are the graphed operating limits.

**HEAT PUMP MODE**

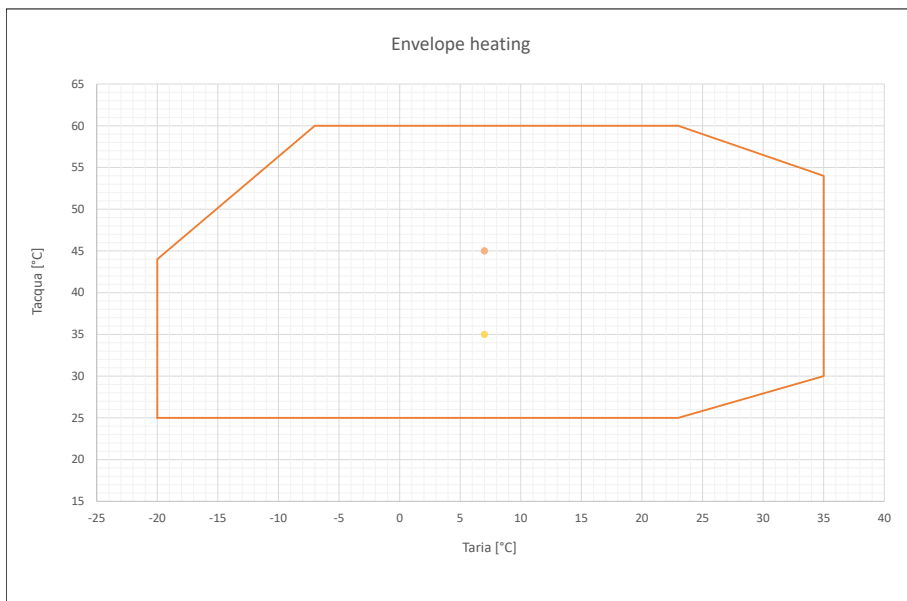

**CHILLER MODE**

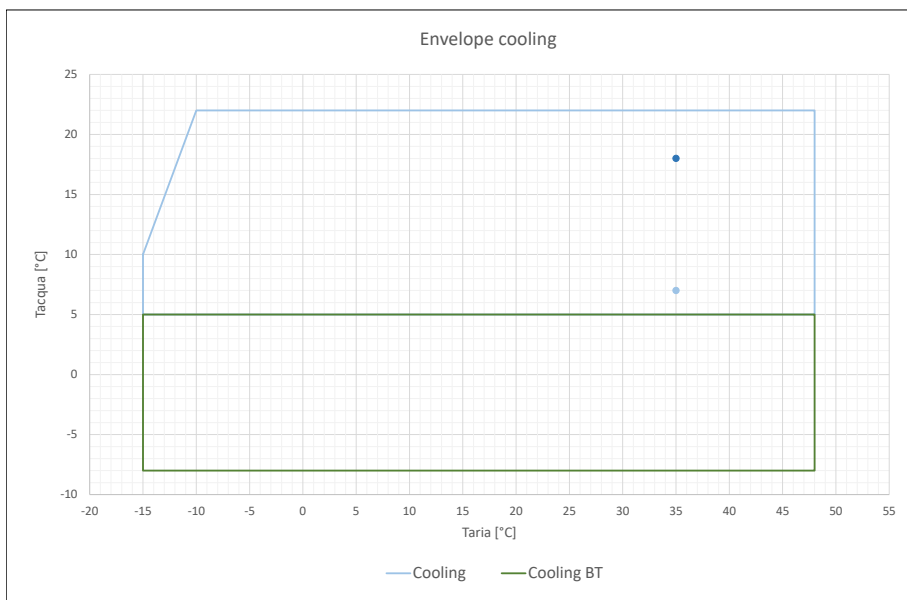

**DOMESTIC HOT WATER MODE**

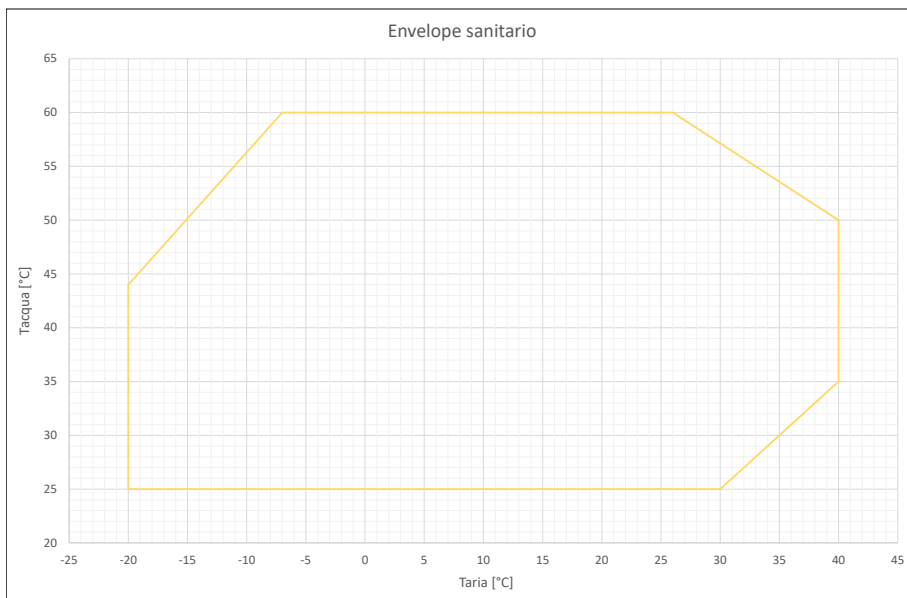

## 9. PERFORMANCE TABLES

The table show the capacity, power input and efficiency values for different outside air temperatures. The data shown are calculated according to EN 14511:2018. They are indicative and may be subject to chang.

### 9.1 HEATING

Model i-32V5H MIDI		HEATING																				
		T Air outdoor [°C]	Tout [°C]																			
			25			30			35			40			45			50			55	
Heating capacity [kW]	Power input [kW]	COP [W/W]	Heating capacity [kW]	Power input [kW]	COP [W/W]	Heating capacity [kW]	Power input [kW]	COP [W/W]	Heating capacity [kW]	Power input [kW]	COP [W/W]	Heating capacity [kW]	Power input [kW]	COP [W/W]	Heating capacity [kW]	Power input [kW]	COP [W/W]	Heating capacity [kW]	Power input [kW]	COP [W/W]		
0121	-15	14,1	5,65	2,50	13,7	5,97	2,29	13,2	6,28	2,10	12,7	6,62	1,92	13,3	7,80	1,71	13,0	8,23	1,58	-1,0	-1,00	-1,00
	-10	15,8	5,74	2,75	15,6	6,21	2,51	15,4	6,66	2,31	15,1	7,12	2,12	16,2	8,49	1,91	16,0	9,09	1,76	15,8	9,74	1,62
	-7	17,8	5,85	3,04	17,5	6,38	2,74	17,3	6,87	2,52	17,0	7,45	2,28	17,9	8,77	2,04	17,5	9,42	1,86	17,4	10,1	1,72
	-2	19,0	5,20	3,65	18,8	5,74	3,28	18,5	6,26	2,96	18,3	6,85	2,67	19,4	8,28	2,34	19,1	8,81	2,17	19,2	9,58	2,00
	2	23,5	5,02	4,68	23,1	5,68	4,07	22,9	6,27	3,65	22,5	7,00	3,21	23,4	8,43	2,78	22,9	9,21	2,49	22,4	9,94	2,25
	7	21,6	3,82	5,65	21,4	4,38	4,89	21,3	4,92	4,33	20,5	5,42	3,78	21,3	6,58	3,24	20,9	7,27	2,87	20,6	7,98	2,58
	12	21,8	3,12	6,99	21,4	3,65	5,86	21,2	4,19	5,06	20,7	4,71	4,39	21,4	5,65	3,79	20,9	6,21	3,37	20,4	6,81	3,00
	15	20,4	2,76	7,39	20,2	3,27	6,18	19,9	3,77	5,28	19,7	4,30	4,58	20,2	5,09	3,97	19,7	5,62	3,51	19,3	6,23	3,10
	20	19,2	2,36	8,14	19,0	2,85	6,67	18,6	3,26	5,71	18,2	3,73	4,88	18,9	4,28	4,42	18,4	4,75	3,87	18,1	5,29	3,42
	25	-1,0	-1,00	-1,00	19,7	2,63	7,49	19,4	3,05	6,36	18,7	3,51	5,33	18,8	3,85	4,88	18,4	4,30	4,28	18,0	4,80	3,75
30	-1,0	-1,00	-1,00	21,1	2,76	7,64	20,8	2,99	6,96	19,5	3,22	6,06	20,4	3,85	5,30	19,9	4,29	4,64	19,3	4,80	4,02	
0126	-15	13,9	5,78	2,40	13,4	6,12	2,19	13,0	6,43	2,02	12,7	6,79	1,87	12,9	7,14	1,81	12,7	7,60	1,67	-1,0	-1,00	-1,00
	-10	15,8	5,94	2,66	15,6	6,36	2,45	15,5	6,85	2,26	15,2	7,34	2,07	15,5	7,74	2,00	15,4	8,35	1,84	15,3	8,99	1,70
	-7	17,8	6,01	2,96	17,5	6,56	2,67	17,3	7,09	2,44	17,1	7,64	2,24	17,3	8,07	2,14	17,1	8,71	1,96	17,0	9,44	1,80
	-2	19,8	5,55	3,57	19,4	6,14	3,16	19,2	6,74	2,85	19,0	7,32	2,60	19,3	7,93	2,43	19,2	8,60	2,23	18,9	9,27	2,04
	2	24,8	5,49	4,52	24,5	6,23	3,93	24,1	6,91	3,49	23,7	7,66	3,09	24,0	8,23	2,92	23,6	8,98	2,63	23,4	9,86	2,37
	7	26,7	5,11	5,23	26,4	5,90	4,47	26,0	6,44	4,04	25,5	7,29	3,50	25,8	7,86	3,28	25,5	8,69	2,93	25,1	9,51	2,64
	12	26,1	3,99	6,54	25,6	4,65	5,51	25,3	5,38	4,70	24,8	6,04	4,11	25,0	6,53	3,83	24,4	7,18	3,40	24,1	8,00	3,01
	15	25,5	3,74	6,82	25,0	4,34	5,76	24,6	4,95	4,97	24,1	5,52	4,37	24,4	6,11	3,99	24,0	6,78	3,54	23,5	7,56	3,11
	20	24,8	3,24	7,65	24,3	3,79	6,41	23,9	4,38	5,46	23,4	4,99	4,69	23,6	5,50	4,29	23,1	6,08	3,80	22,7	6,75	3,36
	25	-1,0	-1,00	-1,00	23,3	3,25	7,17	22,8	3,76	6,06	22,4	4,28	5,23	22,4	4,68	4,79	22,0	5,30	4,15	21,5	5,77	3,73
30	-1,0	-1,00	-1,00	24,8	3,11	7,97	24,4	3,65	6,68	23,9	4,19	5,70	24,2	4,66	5,19	23,6	5,25	4,50	23,0	5,89	3,90	
0128	-15	17,7	6,78	2,61	17,0	7,17	2,37	16,3	7,55	2,16	15,8	7,94	1,99	15,9	8,48	1,88	15,3	8,94	1,71	-1,0	-1,00	-1,00
	-10	19,9	6,89	2,89	19,6	7,46	2,63	19,4	8,02	2,42	19,0	8,57	2,22	18,9	9,19	2,06	18,8	9,90	1,90	18,9	10,8	1,76
	-7	22,3	7,03	3,17	22,1	7,66	2,89	21,7	8,28	2,62	21,4	8,94	2,39	21,2	9,60	2,21	20,8	10,3	2,02	20,9	11,3	1,86
	-2	23,2	5,96	3,89	22,8	6,57	3,47	22,6	7,24	3,12	22,3	7,89	2,83	22,7	9,05	2,51	22,5	9,74	2,31	22,3	10,7	2,09
	2	28,1	5,66	4,96	27,6	6,38	4,33	27,0	7,07	3,82	26,4	7,75	3,41	27,7	9,19	3,01	27,3	10,0	2,72	26,9	11,0	2,45
	7	28,7	4,91	5,85	28,4	5,62	5,05	28,0	6,35	4,41	27,2	6,99	3,89	28,3	8,21	3,45	27,8	9,07	3,07	27,3	9,99	2,73
	12	27,3	3,74	7,30	26,9	4,40	6,11	26,2	4,97	5,27	25,8	5,56	4,64	26,6	6,60	4,03	26,1	7,42	3,52	25,6	8,14	3,14
	15	25,6	3,35	7,64	25,2	3,95	6,38	24,9	4,54	5,48	24,2	5,06	4,78	24,9	5,94	4,19	24,4	6,64	3,67	24,0	7,39	3,25
	20	23,3	2,79	8,35	23,1	3,29	7,02	22,7	3,82	5,94	22,2	4,33	5,13	22,5	5,12	4,39	22,1	5,62	3,93	21,6	6,26	3,45
	25	-1,0	-1,00	-1,00	21,9	2,84	7,71	21,4	3,27	6,54	20,9	3,73	5,60	19,8	4,19	4,73	19,4	4,62	4,20	18,9	5,15	3,67
30	-1,0	-1,00	-1,00	23,5	2,89	8,14	22,9	3,23	7,09	22,3	3,66	6,03	21,1	4,05	5,21	20,6	4,54	4,54	20,2	5,07	3,98	
0132	-15	17,1	6,87	2,49	16,4	7,28	2,25	15,8	7,68	2,06	15,5	8,11	1,91	16,3	9,03	1,81	16,4	9,67	1,70	-1,0	-1,00	-1,00
	-10	19,6	7,03	2,79	19,5	7,63	2,56	19,2	8,21	2,34	18,7	8,73	2,14	19,9	9,85	2,02	19,8	10,6	1,87	19,6	11,5	1,71
	-7	21,9	7,11	3,08	21,7	7,76	2,80	21,4	8,45	2,53	21,0	9,08	2,31	22,1	10,2	2,16	21,8	11,0	1,98	21,7	11,9	1,82
	-2	25,1	6,84	3,67	24,9	7,70	3,23	24,5	8,39	2,92	24,1	9,10	2,65	25,6	10,5	2,45	25,4	11,4	2,23	24,9	12,2	2,04
	2	32,1	7,10	4,52	31,6	7,92	3,99	31,4	8,86	3,54	30,9	9,80	3,15	32,2	11,1	2,90	31,7	12,1	2,61	31,0	13,1	2,37
	7	33,3	6,21	5,36	32,8	7,09	4,63	32,1	7,84	4,09	31,6	8,70	3,63	32,7	9,90	3,30	32,4	11,0	2,96	31,8	12,1	2,64
	12	31,2	4,61	6,77	30,8	5,47	5,63	30,2	6,16	4,90	29,5	6,89	4,28	30,8	7,98	3,86	30,2	8,84	3,42	29,6	9,86	3,00
	15	28,7	3,96	7,25	28,1	4,60	6,11	27,5	5,25	5,24	27,1	5,88	4,61	28,2	6,89	4,09	27,7	7,72	3,59	27,0	8,54	3,16
	20	25,6	3,20	8,00	25,2	3,80	6,63	24,7	4,25	5,81	24,3	4,89	4,97	25,3	5,74	4,41	24,8	6,36	3,90	24,2	7,03	3,44
	25	-1,0	-1,00	-1,00	25,6	3,40	7,53	25,1	3,94	6,37	24,4	4,46	5,47	24,6	5,09	4,83	24,1	5,66	4,26	23,7	6,39	3,71
30	-1,0	-1,00	-1,00	26,2	3,20	8,19	26,0	3,74	6,95	25,4	4,28	5,93	26,5	5,06	5,24	25,9	5,74	4,51	25,2	6,35	3,97	

**9.2 COOLING**

COOLING																			
Model i-32V5H MIDI	T air outdoor [°C]	Tout [°C]																	
		5			7			10			12			15			18		
		Cooling capacity [kW]	Power input [kW]	EER [W/W]	Cooling capacity [kW]	Power input [kW]	EER [W/W]	Cooling capacity [kW]	Power input [kW]	EER [W/W]	Cooling capacity [kW]	Power input [kW]	EER [W/W]	Cooling capacity [kW]	Power input [kW]	EER [W/W]	Cooling capacity [kW]	Power input [kW]	EER [W/W]
0121	20	15,2	3,25	4,68	16,1	3,25	4,95	17,7	3,25	5,45	17,5	2,50	7,00	19,1	2,49	7,67	20,8	2,47	8,42
	25	15,9	3,94	4,04	16,8	3,92	4,29	18,7	3,99	4,69	18,7	3,14	5,96	20,5	3,15	6,51	22,4	3,17	7,07
	30	15,1	4,27	3,54	16,2	4,33	3,74	17,8	4,43	4,02	17,9	3,55	5,04	19,6	3,57	5,49	21,4	3,59	5,96
	35	16,5	5,82	2,84	17,7	5,87	3,02	19,4	6,05	3,21	18,4	4,39	4,19	20,2	4,45	4,54	22,0	4,50	4,89
	40	15,5	6,38	2,43	16,6	6,48	2,56	18,3	6,60	2,77	17,4	4,88	3,57	19,0	4,95	3,84	20,7	5,00	4,14
	45	14,4	6,94	2,07	15,4	7,05	2,18	17,0	7,22	2,35	16,2	5,36	3,02	17,8	5,42	3,28	19,4	5,48	3,54
0126	20	18,2	3,91	4,65	19,4	3,98	4,87	21,3	4,12	5,17	19,1	2,65	7,21	20,9	2,65	7,89	22,7	2,66	8,53
	25	18,4	4,57	4,03	19,6	4,64	4,22	21,5	4,73	4,55	21,0	3,48	6,03	23,0	3,52	6,53	24,9	3,61	6,90
	30	17,5	4,96	3,53	18,7	5,11	3,66	20,5	5,24	3,91	20,1	3,98	5,05	22,0	4,04	5,45	23,9	4,11	5,82
	35	17,7	6,00	2,95	18,7	6,19	3,02	20,6	6,32	3,26	21,9	5,35	4,09	24,0	5,47	4,39	26,2	5,56	4,71
	40	16,5	6,60	2,50	17,5	6,75	2,59	19,3	6,90	2,80	20,7	5,90	3,51	22,6	6,02	3,75	24,5	6,13	4,00
	45	15,4	7,16	2,15	16,4	7,30	2,25	18,1	7,50	2,41	19,3	6,42	3,01	21,1	6,57	3,21	23,0	6,69	3,44
0128	20	22,3	4,76	4,68	23,8	4,80	4,96	26,0	4,83	5,38	23,7	3,70	6,41	25,9	3,71	6,98	28,2	3,72	7,58
	25	23,1	5,88	3,93	24,6	5,95	4,13	27,0	6,09	4,43	25,1	4,65	5,40	27,4	4,73	5,79	29,9	4,80	6,23
	30	22,2	6,44	3,45	23,6	6,54	3,61	26,0	6,72	3,87	24,1	5,19	4,64	26,4	5,27	5,01	28,8	5,36	5,37
	35	22,6	7,86	2,88	24,2	7,98	3,03	26,5	8,22	3,22	24,2	6,19	3,91	26,5	6,31	4,20	29,0	6,36	4,56
	40	21,3	8,60	2,48	22,7	8,75	2,59	24,9	8,97	2,78	22,9	6,84	3,35	25,0	6,95	3,60	27,2	7,06	3,85
	45	19,9	9,30	2,14	21,2	9,50	2,23	23,3	9,74	2,39	21,4	7,45	2,87	23,5	7,56	3,11	25,5	7,68	3,32
0132	20	24,5	5,25	4,67	26,1	5,30	4,92	28,6	5,53	5,17	26,0	4,04	6,44	28,4	4,09	6,94	30,9	4,21	7,34
	25	25,3	6,50	3,89	27,0	6,63	4,07	29,6	6,78	4,37	27,3	5,14	5,31	29,9	5,25	5,70	32,6	5,33	6,12
	30	24,2	7,16	3,38	25,9	7,27	3,56	28,4	7,47	3,80	26,2	5,73	4,57	28,7	5,80	4,95	31,3	5,98	5,23
	35	24,3	8,53	2,85	26,0	8,65	3,01	28,4	9,00	3,16	26,2	6,88	3,81	28,8	7,02	4,10	31,4	7,08	4,44
	40	22,9	9,33	2,45	24,4	9,50	2,57	26,8	9,73	2,75	24,8	7,58	3,27	27,1	7,72	3,51	29,5	7,85	3,76
	45	21,4	10,1	2,12	22,8	10,3	2,22	25,1	10,6	2,38	23,1	8,25	2,80	25,3	8,41	3,01	27,6	8,55	3,23

### 9.3 SANITARY

The tables show the values of heating capacity, power input and COP for different outside air temperatures during the summer season for technical water at 45 / 50 / 55°C for the production of domestic hot water. The data shown are indicative and may subject to change.

HEATING										
Model i-32V5H MIDI	T aria esterna [°C]	Tout [°C]								
		45			50			55		
		Heating capacity [kW]	Power input [kW]	COP [W/W]	Heating capacity [kW]	Power input [kW]	COP [W/W]	Heating capacity [kW]	Power input [kW]	COP [W/W]
0121	20	18,9	4,28	4,42	18,4	4,75	3,87	18,1	5,29	3,42
	25	18,8	3,85	4,88	18,4	4,30	4,28	18,0	4,80	3,75
	30	20,4	3,85	5,30	19,9	4,29	4,64	19,3	4,80	4,02
	35	21,6	3,82	5,65	21,1	4,31	4,90	-	-	-
0126	20	23,6	5,50	4,29	23,1	6,08	3,80	22,7	6,75	3,36
	25	22,4	4,68	4,79	22,0	5,30	4,15	21,5	5,77	3,73
	30	24,2	4,66	5,19	23,6	5,25	4,50	23,0	5,89	3,90
	35	25,8	4,73	5,45	25,1	5,24	4,79	-	-	-
0128	20	22,5	5,12	4,39	22,1	5,62	3,93	21,6	6,26	3,45
	25	19,8	4,19	4,73	19,4	4,62	4,20	18,9	5,15	3,67
	30	21,1	4,05	5,21	20,6	4,54	4,54	20,2	5,07	3,98
	35	22,1	3,93	5,62	21,7	4,44	4,89	-1,0	-1,00	-1,00
0132	20	25,3	5,74	4,41	24,8	6,36	3,90	24,2	7,03	3,44
	25	24,6	5,09	4,83	24,1	5,66	4,26	23,7	6,39	3,71
	30	26,5	5,06	5,24	25,9	5,74	4,51	25,2	6,35	3,97
	35	27,7	4,95	5,60	27,1	5,59	4,85	-	-	-

## 9.4 DATA FOR ENERGY CERTIFICATION OF BUILDINGS ACCORDING TO UNI/TS 11300-4 FOR HEAT PUMPS

The supplementary data of heat pumps for the calculation of the energy performance of buildings according to UNI/TS 11300 part 4 are given below.

The characteristics quantities that will be provided for each model are explained below.

### Legend:

$T_{design}$	Design temperature (for climate A - average, defined by UNI EN 14825 as -10°C)
A, B, C, D	Reference operating conditions for performance evaluation according to UNI EN 14825
$T_{air}$	Reference outdoor air temperature
$T_{water}$	Heating water flow temperature
PLR	<i>Partial Load Ratio</i> - climatic load factor
DC	<i>Declared Capacity</i> - output of the heat pump under operating conditions A, B, C, D
$COP_{DC}$	COP of the heat pump referred to nominal conditions DC
$COP_{PL}$	COP della pompa di calore nelle condizioni di parzializzazione definite dalla norma UNI EN 14825

### 9.4.1 Model i-32V5H MIDI 0121

#### Operating limits

COLD source		OUTDOOR AIR	
Operating temperature (cut-off)		min	-20°C
		max	35°C
HOT source		WATER	
Operating temperature (cut-off)		min	25°C
		max	60°C

#### Useful heating capacity / COP at nominal conditions with defrosting contribution

Useful heating capacity [kW]			
$T_{air}$ (cold source)	$T_{water}$ (hot source)		
	35	45	55
-7	17,3	17,9	17,4
2	22,9	23,4	22,4
7	21,3	21,3	20,6
12	21,2	21,4	20,4

$COP_{DC}$			
$T_{air}$ (hot source)	$T_{water}$ (hot source)		
	35	45	55
-7	2,52	2,04	1,72
2	3,65	2,78	2,25
7	4,33	3,24	2,58
12	5,06	3,79	3,00

#### Performance data measured under partial load conditions according to UNI EN 14825

Operating conditions		F	A (E)	B	C	D
$T_{air}$	[°C]	-10	-7	2	7	12
PLR	[%]	100	88	54	35	15
<b>Power DC (Declared Capacity)</b>	[kW]	15,5	17,3	10,6	9,3	10,9
$COP_{PL}$		2,31	2,54	4,24	5,15	7,08
$COP_{DC}$		2,31	2,52	3,65	4,33	5,06

#### Performance

35 °C		
SCOP	$\eta_s$	Energy class
4,20	165%	A++



## 9.4.2 Model i-32V5H MIDI 0126

### Operating limits

COLD source		OUTDOOR AIR	
Operating temperature (cut-off)		min	-20°C
		max	35°C
HOT source		WATER	
Operating temperature (cut-off)		min	25°C
		max	60°C

### Useful heating capacity / COP at nominal conditions with defrosting contribution

Useful heating capacity [kW]			
T <sub>air</sub> (cold source)	T <sub>water</sub> (hot source)		
	35	45	55
-7	17,3	17,3	17,0
2	24,1	24,0	23,4
7	26,0	25,8	25,1
12	25,3	25,0	24,1

COP <sub>DC</sub>			
T <sub>air</sub> (cold source)	T <sub>water</sub> (hot source)		
	35	45	55
-7	2,44	2,14	1,80
2	3,49	2,92	2,37
7	4,04	3,28	2,64
12	4,70	3,83	2,64

### Performance data measured under partial load conditions according to UNI EN 14825

Operating conditions		F	A (E)	B	C	D
T <sub>air</sub>	[°C]	-10	-7	2	7	12
PLR	[%]	100	88	54	35	15
Power DC (Declared Capacity)	[kW]	15,4	17,4	10,6	9,3	10,7
COP <sub>PL</sub>		2,27	2,49	3,93	4,88	6,53
COP <sub>DC</sub>		2,26	2,44	3,49	4,04	4,70

### Performance

35 °C		
SCOP	η <sub>s</sub>	Energy class
3,95	155%	A++

## 9.4.3 Model i-32V5H MIDI 0128

### Operating limits

COLD source		OUTDOOR AIR	
Operating temperature (cut-off)		min	-20°C
		max	35°C
HOT source		WATER	
Operating temperature (cut-off)		min	25°C
		max	60°C

**Useful heating capacity / COP at nominal conditions with defrosting contribution**

Useful heating capacity [kW]			
T <sub>air</sub> (cold source)	T <sub>water</sub> (hot source)		
	35	45	55
-7	21,7	21,2	20,9
2	27,0	27,7	26,9
7	28,0	28,3	27,3
12	26,2	26,6	25,6

COP <sub>DC</sub>			
T <sub>air</sub> (cold source)	T <sub>water</sub> (hot source)		
	35	45	55
-7	2,62	2,21	1,86
2	3,82	3,01	2,45
7	4,41	3,45	2,73
12	5,27	4,03	3,14

**Performance data measured under partial load conditions according to UNI EN 14825**

Operating conditions		F	A (E)	B	C	D
T <sub>air</sub>	[°C]	-10	-7	2	7	12
PLR	[%]	100	88	54	35	15
Power DC (Declared Capacity)	[kW]	19,3	21,7	13,2	11,9	13,7
COP <sub>PL</sub>		2,41	2,68	4,26	5,39	7,06
COP <sub>DC</sub>		2,42	2,62	3,82	4,41	5,27

**Performances**

35 °C		
SCOP	η <sub>s</sub>	Energy class
4,29	169%	A++

**9.4.4 Model i-32V5H MIDI 0132**
**Operating limits**

COLD source		OUTDOOR AIR	
Operating temperature (cut-off)		min	-20°C
		max	35°C
HOT source		WATER	
Operating temperature (cut-off)		min	25°C
		max	60°C

**Useful heating capacity / COP at nominal conditions with defrosting contribution**

Useful heating capacity [kW]			
T <sub>air</sub> (cold source)	T <sub>water</sub> (hot source)		
	35	45	55
-7	21,4	22,1	21,7
2	31,4	32,2	31,0
7	32,1	32,7	31,8
12	30,2	30,8	29,6

COP <sub>DC</sub>			
T <sub>air</sub> (cold source)	T <sub>water</sub> (hot source)		
	35	45	55
-7	2,53	2,16	1,82
2	3,54	2,90	2,37
7	4,09	3,30	2,64
12	4,90	3,86	3,00

**Performance data measured under partial load conditions according to UNI EN 14825**

Operating conditions		F	A (E)	B	C	D
T <sub>air</sub>	[°C]	-10	-7	2	7	12
PLR	[%]	100	88	54	35	15
Power DC (Declared Capacity)	[kW]	18,8	21,3	13,0	11,6	13,5

Operating conditions		F	A (E)	B	C	D
<b>COP<sub>PL</sub></b>		2,29	2,57	3,94	5,03	6,96
<b>COP<sub>DC</sub></b>		2,34	2,53	3,54	4,09	4,90

**Performances**

		35 °C	
SCOP		ηs	Energy class
4,02		158%	A++

## 9.5 EER VALUES FOR CALCULATING THE ENERGY PERFORMANCE OF BUILDINGS ACCORDING TO UNI/TS 11300-3

The cooling capacity values and EER coefficients under partial load conditions are shown below. The reference conditions at partial load specified by UNI/TS 11300-3 are illustrated below. EER are also provided for load factors below 25%

Test	Charge factor	Outside air dry bulb temperature	Chilled water temperature at fan inlet/outlet
1	100%	35	12/7
2	75%	30	*)/7
3	50%	25	*)/7
4	25%	20	*)/7

\*) Temperature determined by water flow rate at full load.

### 9.5.1 Model i-32V5H MIDI 0121

Outside air dry bulb temperature [°C]	Charge factor F%	EER	Cooling capacity [kW]
35	100%	3,00	17,7
30	75%	4,03	12,9
25	50%	4,89	8,8
20	25%	5,14	9,5

C	Charge factor F%	EER @20°C xC
0,95	20%	5,64
0,94	15%	5,58
0,87	10%	5,17
0,71	5%	4,22
0,46	2%	2,73
0,29	1%	1,72

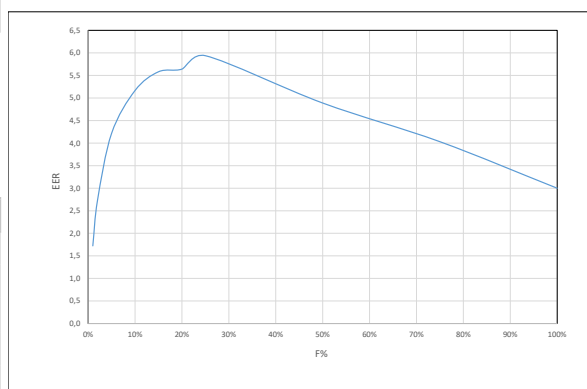

### 9.5.2 Model i-32V5H MIDI 0126

Outside air dry bulb temperature [°C]	Charge factor F%	EER	Cooling capacity [kW]
35	100%	3,02	18,7
30	75%	4,15	13,7
25	50%	5,00	9,0
20	25%	5,28	9,7

C	Charge factor F%	EER @20°C xC
0,95	20%	5,76
0,94	15%	5,70
0,87	10%	5,27
0,71	5%	4,30
0,46	2%	2,79
0,29	1%	1,76

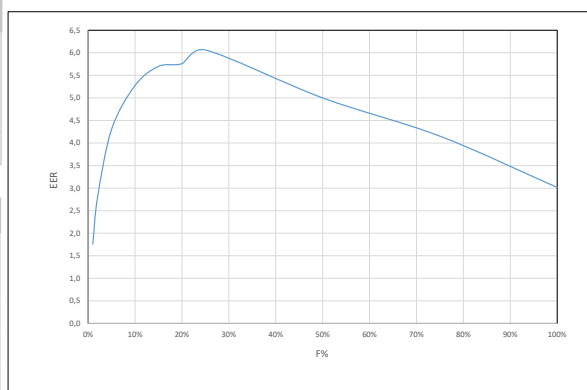

**9.5.3 Model i-32V5H MIDI 0128**

Outside air dry bulb temperature [°C]	Charge factor F%	EER	Cooling capacity [kW]
35	100%	3,01	24,1
30	75%	4,12	17,7
25	50%	5,38	11,3
20	25%	5,67	12,3

C	Charge factor F%	EER @20°C xC
0,95	20%	6,15
0,94	15%	6,09
0,87	10%	5,63
0,71	5%	4,60
0,46	2%	2,98
0,29	1%	1,88

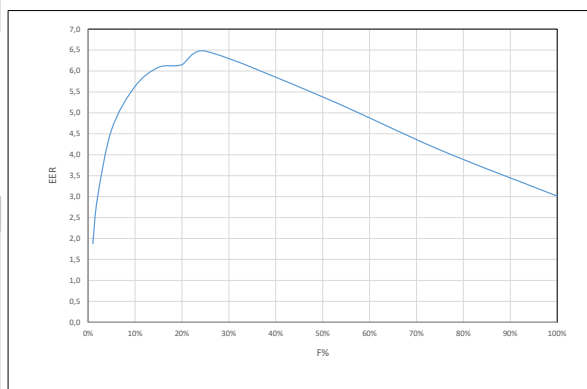

**9.5.4 Model i-32V5H MIDI 0132**

Outside air dry bulb temperature [°C]	Charge factor F%	EER	Cooling capacity [kW]
35	100%	3,02	26,0
30	75%	4,15	19,1
25	50%	5,35	12,3
20	25%	5,87	12,6

C	Charge factor F%	EER @20°C xC
0,95	20%	6,30
0,94	15%	6,23
0,87	10%	5,77
0,71	5%	4,71
0,46	2%	3,05
0,29	1%	1,92

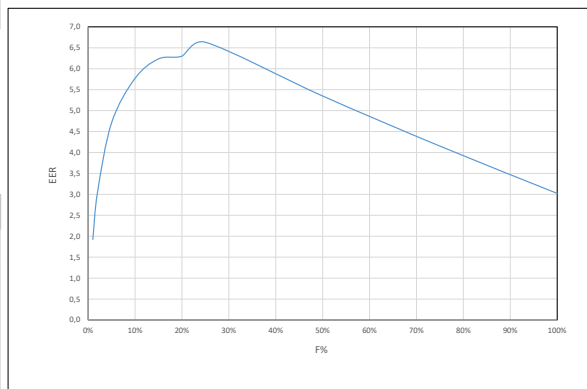

## 10. REFRIGERANT SAFETY SHEET

<b>Name:</b>	R32
<b>HAZARDS IDENTIFICATION</b>	
<b>Main hazards:</b>	Asphyxiation.
<b>Specific hazards:</b>	Quick evaporation could cause it to freeze.
<b>FIRST AID MEASURES</b>	
<b>General information:</b>	Do not administer to people who are unconscious.
<b>Inhalation:</b>	Immediately remove to fresh air. Use oxygen or artificial respiration as required. The use of adrenaline or similar drugs should be avoided.
<b>Eye contact:</b>	Carefully rinse with plenty of water for at least 15 minutes and get medical attention.
<b>Skin contact:</b>	Wash immediately with plenty of water for at least 15 minutes. Apply a sterile gauze. Immediately remove contaminated clothing.
<b>FIRE FIGHTING MEASURES</b>	
<b>Extinguishing media:</b>	Water spray, dry powder.
<b>Specific hazards:</b>	Breakage or explosion of vessel.
<b>Specific methods:</b>	Cool down the containers with a water spray from a safe position. Stop the product leakage if possible. Use water spray, if possible, to abate the fumes. Move the vessels away from the area of the fire if this can be done without posing any risks.
<b>ACCIDENTAL RELEASE MEASURES</b>	
<b>Personal precautions:</b>	Try to stop the leak. Evacuate personnel to safety areas. Ventilate appropriately. Eliminate the ignition sources. Use personal protective equipment.
<b>Environmental precautions:</b>	Try to stop the leak.
<b>Cleaning methods:</b>	Ventilate the area
<b>HANDLING AND STORAGE</b>	
<b>Handling: technical measures/precautions:</b>	Allow efficient air exchange and/or suction the work environments.
<b>Advice for safe use:</b>	Do not breath in fumes or aerosol.
<b>Storage:</b>	Close carefully and store in a cool, dry and well ventilated area. Keep in original containers. Incompatible products: explosive, flammable materials, organic peroxide
<b>EXPOSURE CONTROLS/PERSONAL PROTECTION</b>	
<b>Control parameters:</b>	OEL – data not available. DNEL: Derived no effect level (workers) long-term – systemic effects, inhalation = 7035 mg/m <sup>3</sup> . PNEC: Predicted no-effect concentration water (fresh water) = 0,142 mg/l aquatic, intermittent releases = 1,42 mg/l sediment, fresh water = 0,534 mg/kg dry weight
<b>Respiratory protection:</b>	Not required.
<b>Eye protection:</b>	Safety goggles.
<b>Hand protection:</b>	Latex gloves
<b>Hygienic measures:</b>	No smoking
<b>PHYSICAL AND CHIMICAL PROPERTIES</b>	
<b>Colour:</b>	Colourless.
<b>Odour:</b>	Ethereal. Hard to perceive at low concentrations.
<b>Boiling point:</b>	-51,7 °C at atm press
<b>Flash point:</b>	648 °C
<b>Relative gas density (air=1)</b>	1,8
<b>Relative liquid density (water=1)</b>	1,1
<b>Solubility in water:</b>	280000 mg/l.
<b>STABILITY AND REACTIVITY</b>	
<b>Stability:</b>	Stable under normal conditions.
<b>Materials to avoid: Decomposition products hazardous:</b>	Air, oxidizing agents, humidity. Under normal storage and use conditions, hazardous decomposition products should not be generated..
<b>TOXICOLOGICAL INFORMATION</b>	
<b>Acute toxicity: Local effects: Long term toxicity:</b>	LD/LC50/inHALATION/4 hours/on rat = 1107000 mg/m <sup>3</sup> . No known effect. No kown effect.
<b>ENVIRONMENTAL INFORMATION</b>	
<b>Global warming potential GWP (R744=1):</b>	675
<b>Ozone Depletion Potential ODP (R11=1):</b>	0
<b>Disposal consideration:</b>	Refer to the supplier's gas retrieval program. Avoid direct release into the atmosphere.



**ADVANTIX SpA**  
Via S. Giuseppe Lavoratore 24,  
37040 Arcole (VR) Italy  
Tel. (+39).045.76.36.585  
E-mail: [info@advantixspa.it](mailto:info@advantixspa.it)  
[www.maxa.it](http://www.maxa.it)