



www.regulus.eu



CSE2 MIX F W 1F

**Installation and Operation Manual
CSE2 MIX F W 1F PUMP STATION**

EN

CSE2 MIX F W 1F

Contents

1.	INTRODUCTION	3
2.	PUMP STATION DESCRIPTION AND DATA	3
3.	PUMP STATION COMPONENTS	4
3.1.	WILO PARA 25/8 SC PUMP	5
3.2.	AVC ACTUATOR FOR MIXING VALVE	9
3.3.	LK 840 MIXING VALVE	10
3.4.	CHECK VALVE	11
3.5.	FILTER WITH MAGNET	11
3.6.	BALL VALVES	12
4.	PUMP STATION INSTALLATION	13
5.	TEMPERATURE SENSOR INSTALLATION	14
6.	OPTIONAL ACCESSORIES	15

1. INTRODUCTION

CSE2 MIX F W 1F twin-line pump station is designed for mixed heating circuits. It provides flow through the heating system, mixes to the outlet temperature using a motorized mixing valve (controlled by an external controller). The pump station includes a filter with magnet, so it is also suitable for older steel pipe systems. It can be easily mounted on a wall or on a manifold for multiple heating circuits.

2. PUMP STATION DESCRIPTION AND DATA

Main Features	
Description	The pump station consists of: <ul style="list-style-type: none"> ● Wilo Para 25/8 SC pump ● 2 ball valves w. sensor sheath ● check valve ● filter with strainer&magnet ● LK 840 actuated mixing valve ● thermometers, insulation
Working fluid	water, antifreeze heat-transfer fluid for heating systems
Installation	vertically on a wall or manifold (125 mm pitch)*
Connections	4 x G 1" F
Code	17937

* A set of manifold connecting fittings can be purchased as optional accessories (see chapter 6)

Data for CSE2 MIX F W 1F Pump Station	
Fluid working temperature	5 - 90 °C
Max. working pressure	10 bar
Min. working pressure	0.5 bar
Ambient temperature	5 - 40 °C
Max. relative humidity	80%, non condensing
Pump power supply	1 ~ 230 V, 50 - 60 Hz
Mixing valve power supply	230 V, 50 Hz; from external controller w. 3-point control
Insulation material	EPP RG 60 g/l
Overall dimensions	360 x 133 x 245 mm
Total weight	6.7 kg

3. PUMP STATION COMPONENTS

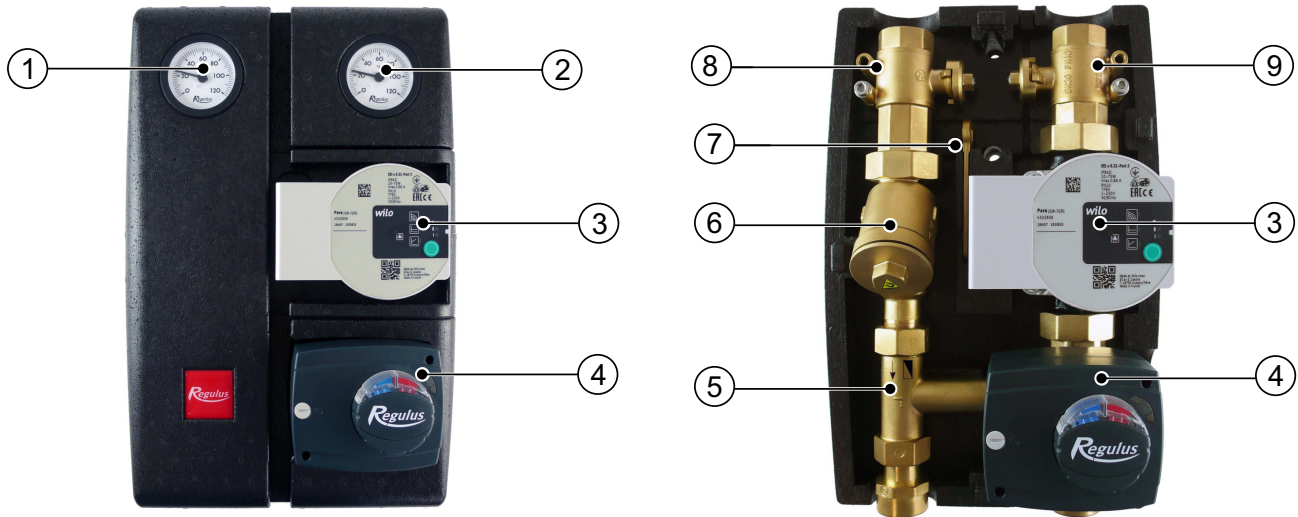

- 1 – Thermometer at the heating circuit outlet
- 2 – Thermometer at the heating circuit inlet
- 3 – Wilo Para 25/8 SC circulation pump
- 4 – 3-point control AVC actuator with LK 840 mixing valve
- 5 – Check valve
- 6 – Dirt filter with magnet
- 7 – Lever for ball valves
- 8 – Ball valve w. sheath for temperature sensor (heating circuit outlet)
- 9 – Ball valve w. sheath for temperature sensor (heating circuit inlet)

3.1. WILO PARA 25/8 SC PUMP

Wilo Para 25/8 SC circulation pump is a wet-running circulation pump permitting to set speed control to $\Delta p-v$, $\Delta p-c$ or $n=\text{constant}$. The operating status and possible faults of the pump are displayed by means of LEDs directly on the pump display. It is used exclusively for the circulation of liquids in hot water heating systems. Operating the pump in other systems or in systems lacking water, containing air bubbles or not pressurized can lead to its rapid destruction.

Wilo Para 25/8 SC Pump Data	
Power supply	230 V, 50 Hz
Power input (min./max)	2 / 75 W
Current (min./max)	0.03 – 0.66 A
Max. speed	4800 rpm
Speed control	frequency converter
Energy Efficiency Index (EEI)	≤ 0.21 by EN 16297/3
IP rating	IPX4D
Motor protection	integrated

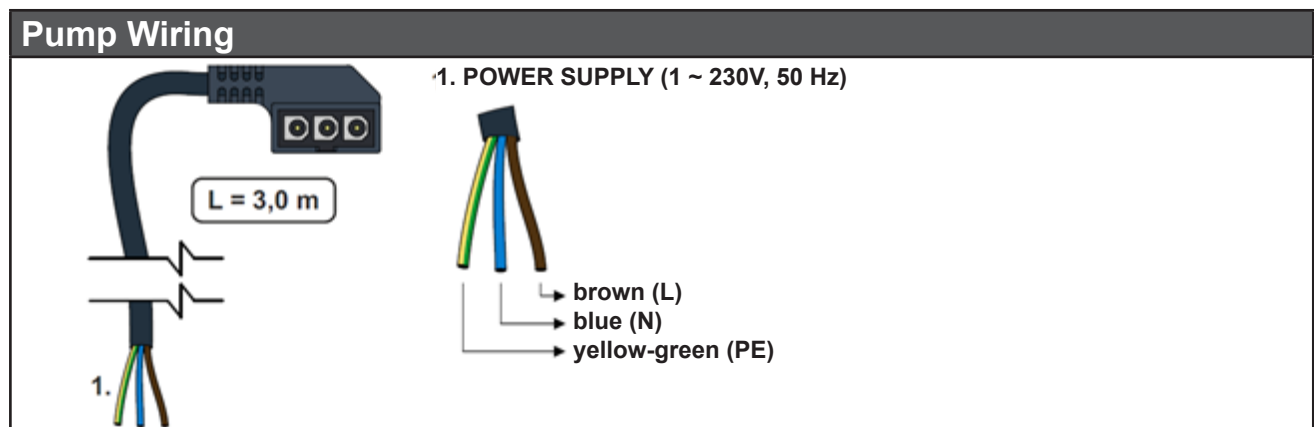

FAULT INDICATION

LED signals	State description and possible fault reasons	
	GREEN IS LIT	1 - pump is running in trouble-free operation
	RED IS LIT	1 - rotor is blocked 2 - electric motor winding defect
	FLASHING RED	1 - power supply lower/higher than 230 V 2 - electric short circuit in pump 3 - pump overheated
	FLASHING RED AND GREEN	1 - unforced fluid circulation through the pump 2 - pump speed lower than desired 3 - air in pump

TROUBLESHOOTING, RESTART, FACTORY SETTINGS

If air is present in the pump:

Activate the pump venting function by pressing and holding the operating button for 3 sec. The upper and lower rows of LEDs will flash in 1sec interval, see Fig.

Pump venting takes 10 minutes, after that the pump returns to current mode. In order to cancel pump venting, press and hold the operating button for 3 sec.



Operating button locking/unlocking

To lock the operating button, press it for 8 seconds.

The selected setting then starts flashing and cannot be changed. To unlock, hold down the operating button again for 8 seconds and the LEDs will stop flashing.



Manual restart

If the pump has been inactive for a long time or is blocked, activate the manual restart by holding the operating button for 5 seconds. The LEDs flash sequentially clockwise. The manual restart takes max. 10 minutes before the pump returns to normal operation. To cancel the manual restart, hold down the operating button for 5 seconds.

If the pump does not get unblocked, contact a qualified technician.



Factory settings

To return to the factory settings, press and hold the operating button for at least 4 seconds (all LEDs flash for 1 second) and turn off the pump by unplugging. When switched on again, the pump will run at the factory settings.

PUMP CONTROL

Constant speed operating mode and pump performance curve III are preset as factory settings for the PARA SC pump. After switching on, the pump runs at the factory setting or at the last setting. The settings can be changed using the operating button, see below.

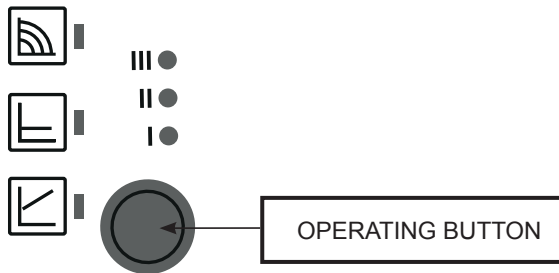

Briefly press the control button to:

select the pump operating mode: constant speed, Δp -v or Δp -c and the pump performance curve (I,II,III).

Press and hold the operating button for the specified time to activate:

- Pump venting function - hold the control button for 3 seconds.
- Manual restart - hold the operating button for 5 seconds.
- Locking/unlocking the operating button - hold the button for 8 seconds.
- Factory setting - hold the control button for at least 4 seconds and switch off the pump by disconnecting it from the mains.

SETTING THE PUMP SPEED CONTROL MANNER

Briefly press the operating button for 1 second to select the pump speed control manner and pump performance curve. LEDs show pump settings (operating mode Δp -v / Δp -c / n =const and the respective performance curve).

	LED indicators	Operating mode	Performance curve
1		constant speed	II
2		constant speed	I
3		Δp -v variable	III
4		Δp -v variable	II
5		Δp -v variable	I
6		Δp -c constant	III
7		Δp -c constant	II
8		Δp -c constant	I
9		constant speed	III

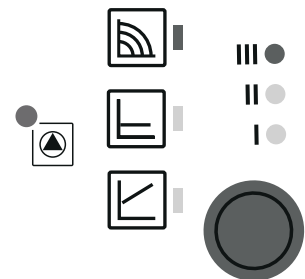

PUMP SPEED CONTROL

The following speed control can be selected:

- Variable differential pressure
- Constant differential pressure
- Constant speed

$\Delta p-v$
 $\Delta p-c$
 $n=const.$



Variable differential pressure ($\Delta p-v$)

This profile is suitable for use with two-line radiator heating systems to reduce the noise caused by the flow of liquid through thermostatic valves. If the flow in the pipe network decreases, the pump reduces the head in half. This saves electrical energy by adapting the head to the pumping capacity requirement and lower flow velocities.

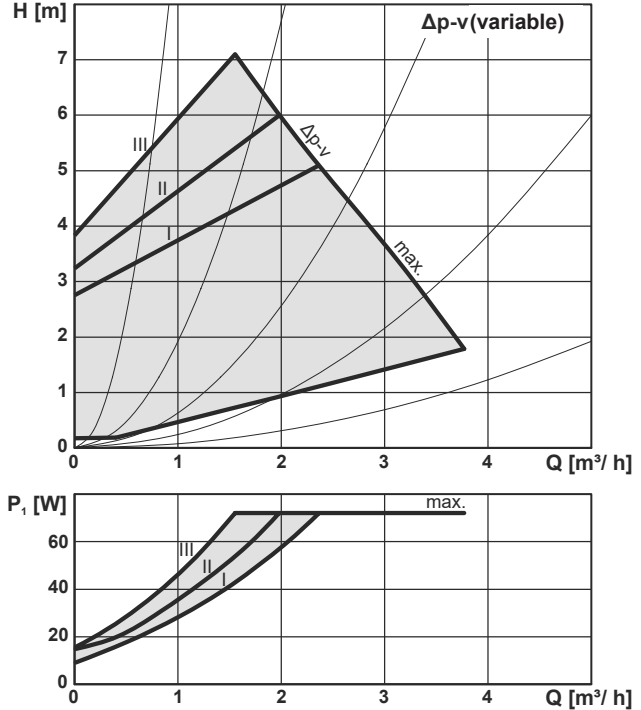

Constant differential pressure ($\Delta p-c$)

This profile is suitable for use in underfloor heating or for piping of bigger diameters. It is also suitable for all applications without variable characteristics (e.g. pumps for HW storage tank heating) and for single-line heating systems with radiators. The pump maintains a constant set delivery head regardless of pumping capacity.

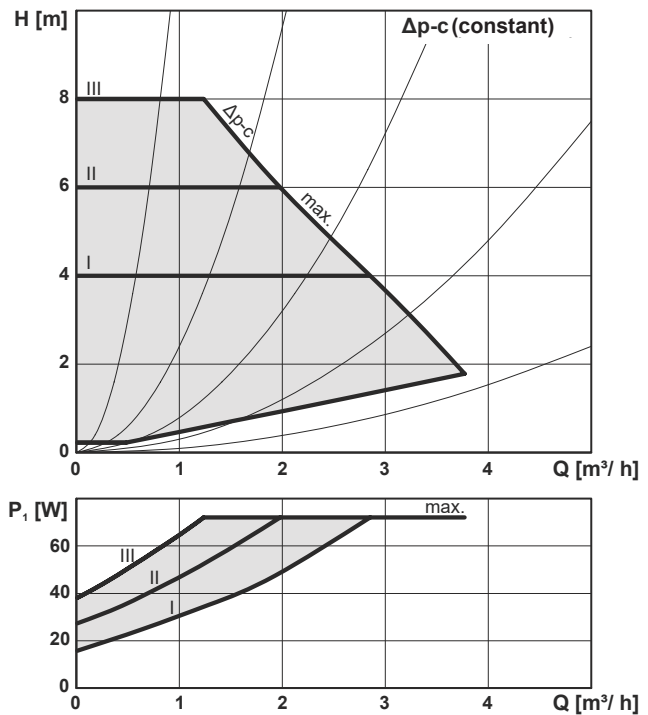



Constant speed (n=const.)

This profile is suitable for use in constant resistance systems that require constant pumping capacity. The pump runs uncontrolled in three preset constant speed stages.

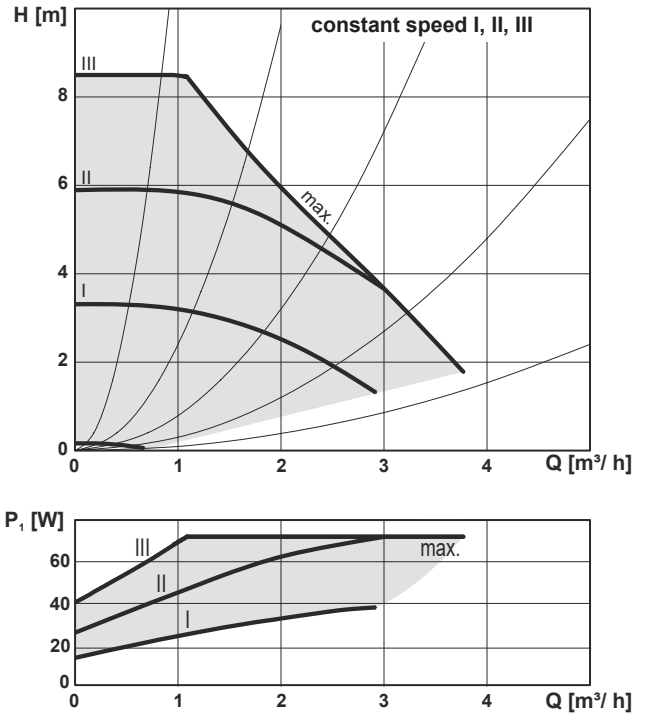

3.2. AVC ACTUATOR FOR MIXING VALVE

LK 840 mixing valve is controlled by an AVC actuator with three-point control. The current position of the valve member can be read from the sight glass on the actuator housing. The control mode switch is used to set automatic or manual control. If manual control is set, the actuator is controlled by turning the control knob.

Technical Data	
Torque	5 Nm
Angle of rotation	90°
Shift time	120 s
Control	3-point
Auxiliary switch	no
Power supply	230 V AC
Max. power input	2.5 VA
IP rating	IP42
Protection class	II by EN 60730-1
Ambient temperature	0 - 40 °C
Cable (cross section - length)	3 x 0.5 mm ² - 2 m

AVC ACTUATOR ELECTRICAL WIRING

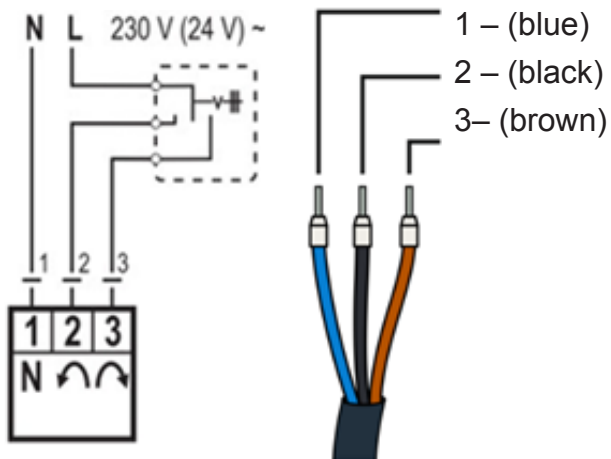

The actuator is factory-set and ready for operation. If it needs to be removed or replaced, follow the instructions in the appendix.

3.3. LK 840 MIXING VALVE

Technical Data

Max. working temperature	5 - 110 °C (120 °C in short term)
Max. working pressure	10 bar
Ambient working temperature	5 - 60 °C
Valve Kvs	6.3 m ³ /h
Max. pressure difference	5 mH ₂ O
Leak rate	< 1 % K _v at 5 m H ₂ O pressure difference
Connections	3 x G 1" M

Materials

Valve housing, spindle and member	brass
Gasket	EPDM

Mixing Valve Pressure Drop Diagram

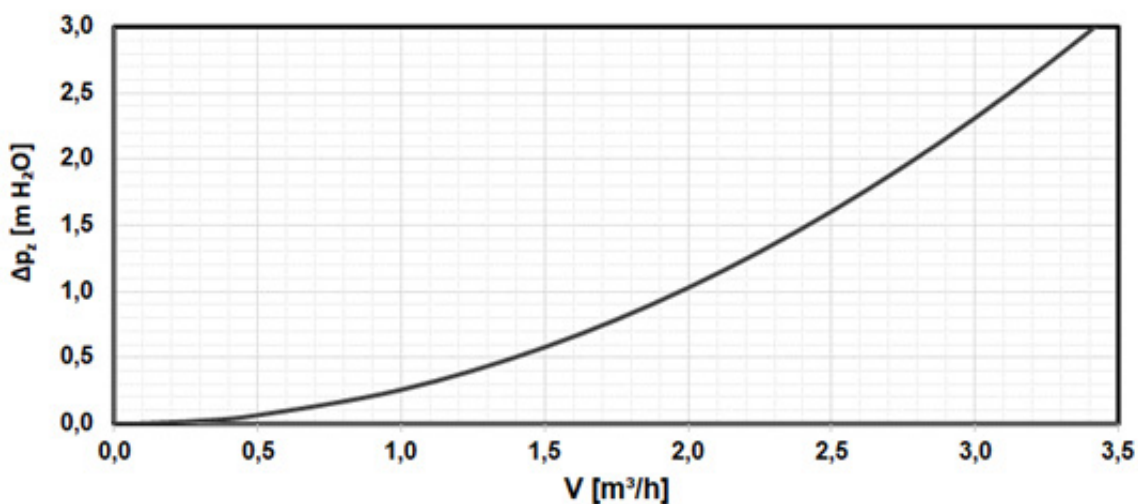

3.4. CHECK VALVE

The check valve downstream of the filter prevents natural circulation in the heating circuit.

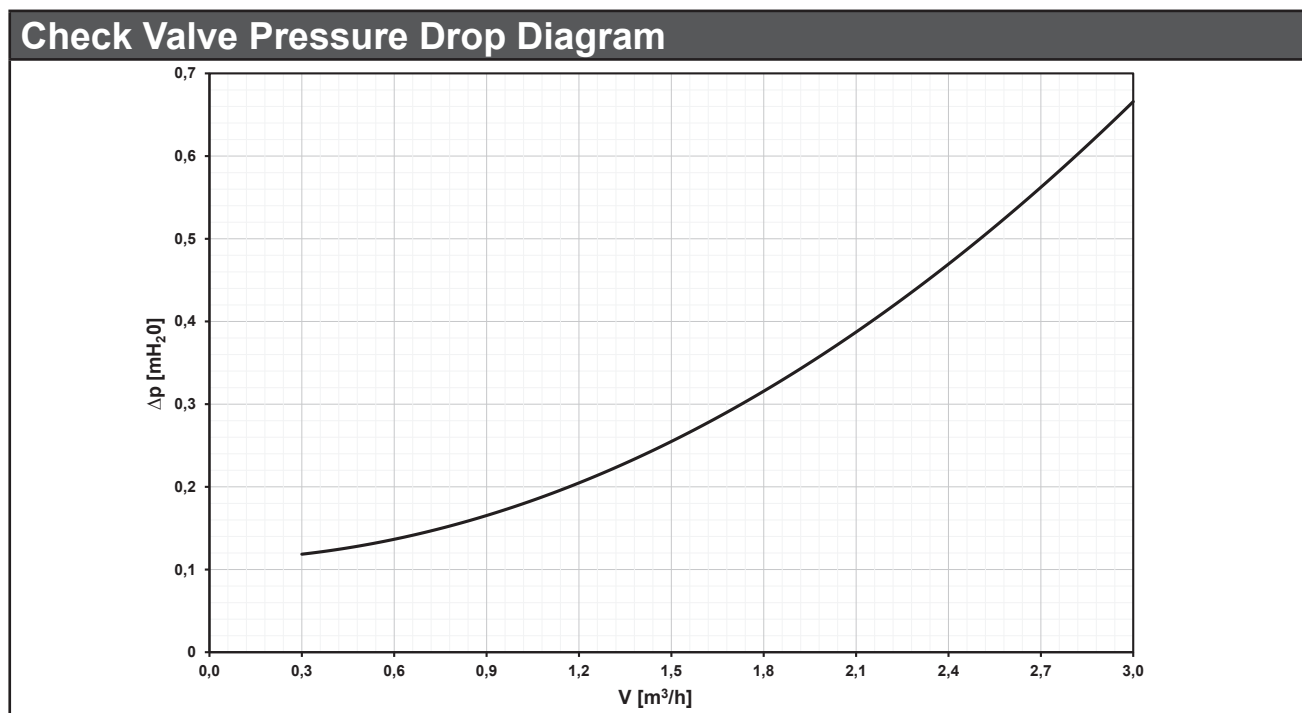

3.5. FILTER WITH MAGNET

The filter located on the return line of the pump station is designed to collect solid particles from the working fluid. It consists of a brass housing, a removable metal strainer collecting coarse impurities and a brass cap with magnet that collects magnetic impurities.

The filter should be checked regularly and cleaned if necessary. The filter shall be cleaned with the circulation pump switched off and the section where the filter is installed shut off. In the section upstream of the filter, shutting off is done by a ball valve, in the section downstream of the filter the piping is shut off by a check valve. The filter cap needs to be unscrewed, the metal strainer removed and rinsed thoroughly from any dirt. Dirt trapped on the magnet must be wiped off and then reassembled by inserting the strainer, screwing in and tightening the cap.

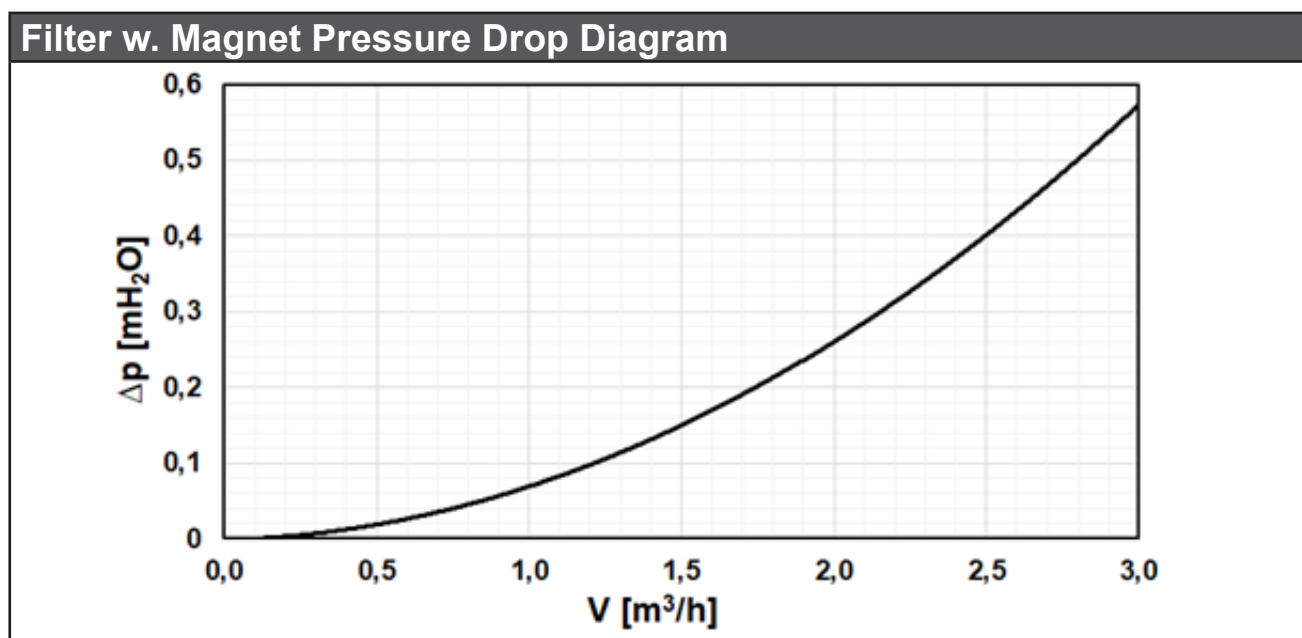

3.6. BALL VALVES

Technical Data	
Kv value	20.2 m ³ /h

Ball valves are intended to isolate the pump station from the heating circuit. Then it is not necessary to drain the heating circuit for servicing (incl. cleaning the filter). In order to have a more solid hydraulic section of the pump station, they are fixed to the rear mounting plate.

The ball valves are controlled by a lever that is not present on the valve during operation. The valve is closed by turning the lever clockwise by 90°. The open / closed position on the ball valve is indicated by a groove on the control wheel. The groove is perpendicular to the direction of flow when the ball valve is closed. The ball valve opens by turning the lever anti-clockwise by 90°, the groove is then in the flow direction. Before closing / opening the ball valve, the top section of the insulation shall be removed first. As a result, unintentional closure of the system by an unauthorized person is not possible.

OPEN

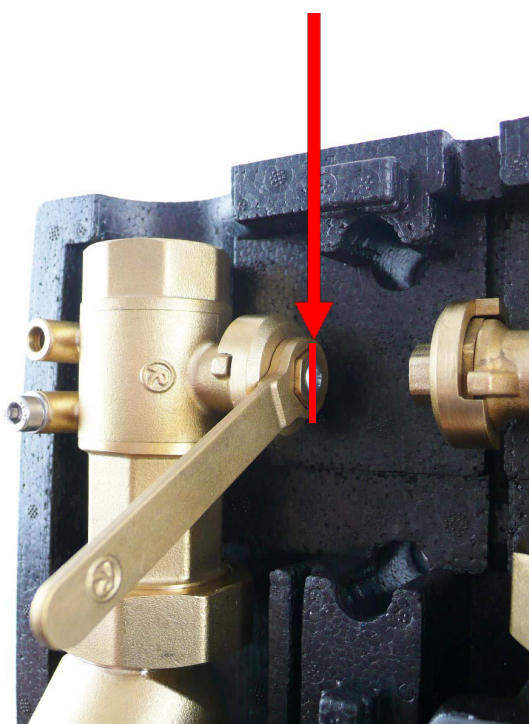

groove in the flow direction

CLOSED

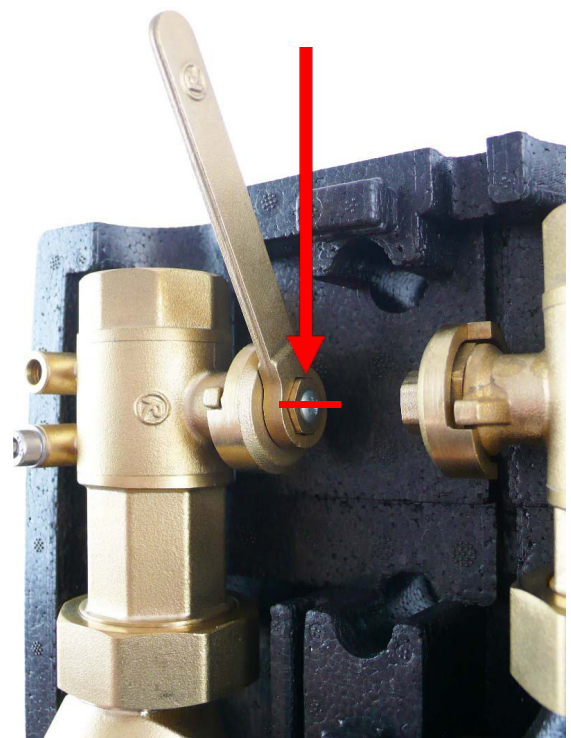

groove perpendicular to the flow direction

4. PUMP STATION INSTALLATION

The load unit is designed to be mounted on a wall or a manifold with 125 mm connection pitch. In the rear section of the insulation there are two mounting holes for fixing the metal plate to the wall. Mounting holes pitch is 175 mm.

Installation dimensions are shown in the figure below.

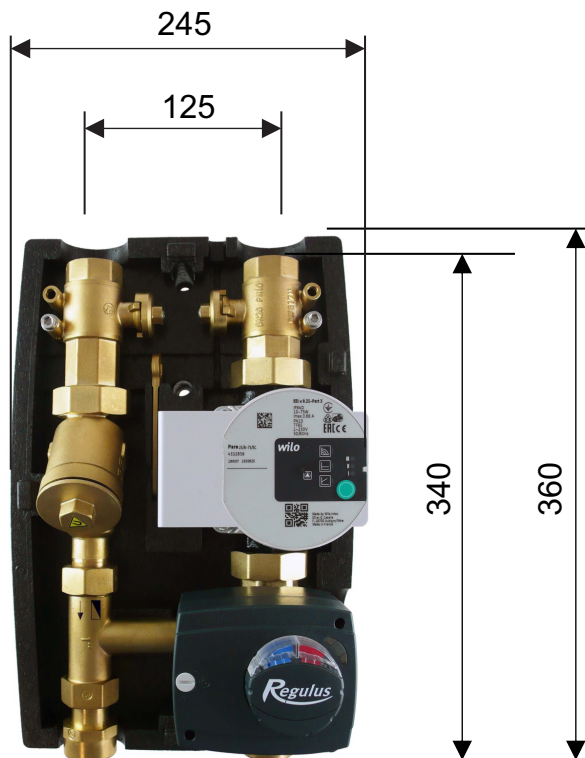

The package includes a mounting kit that is used to fix the pump station to the intended place.



The mounting kit includes:



Screw 5x50, round head	2 pcs
6.4 stainless steel washer, DIN 9021/A2	2 pcs
Wall plug 8mm TX	2 pcs

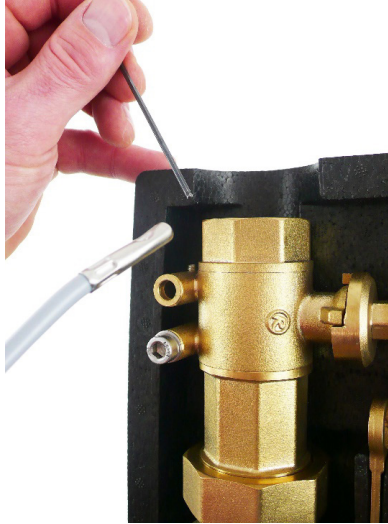

5. TEMPERATURE SENSOR INSTALLATION

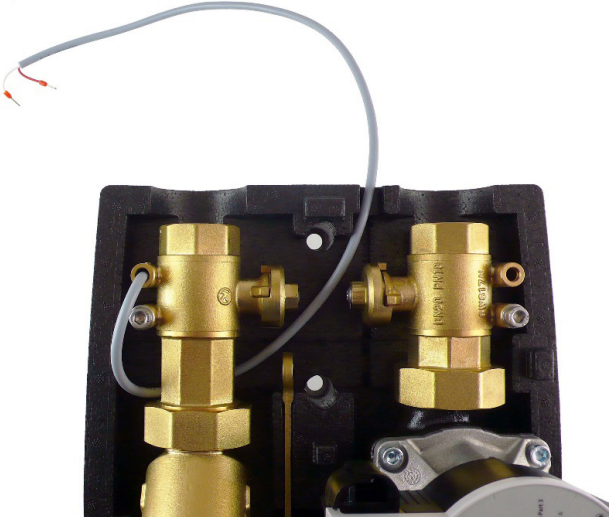
The ball valve housings are equipped with a sheath for the temperature sensor, where the sensor can be inserted and secured by a fixing screw against being pulled out. In the top and bottom section of the insulation there are passages to run the cables through, then it is necessary to cut the appropriate part of the passage lock from the front part of the insulation with a knife, so that the exiting cables are firmly wrapped around by the lock.

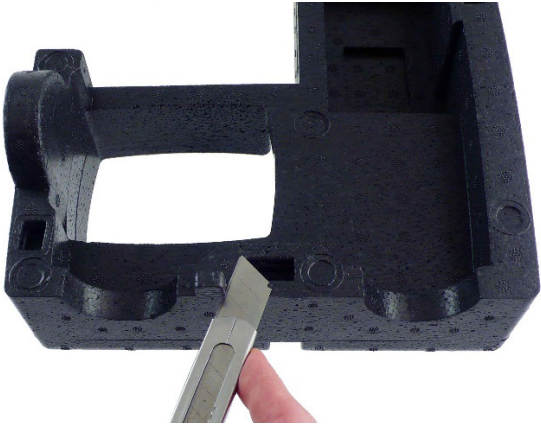
<p>1.</p> <p>Temperature sensor placement</p>	
<p>2.</p> <p>Securing the temperature sensor with the screw</p>	
<p>3.</p> <p>Running the sensor cable through the recess in the insulation</p>	

<p>4.</p> <p>Trimming the cable passage lock</p>	
<p>5.</p> <p>Installed sensors</p>	

6. OPTIONAL ACCESSORIES

The following optional accessories are available for the pump station:

- set of two ball valves with drain valve G 1" Fu x G 1" F x G 1/2" M with manifold connection fittings
Code 17928

- G 1" Fu x G 5/4" F manifold connection fittings
Code 17920



code 17928

APPENDIX – AVC ACTUATOR ADJUSTMENT

- The actuator is set and ready for operation from the production
- The instructions apply only if the actuator had to be removed e.g. to be replaced

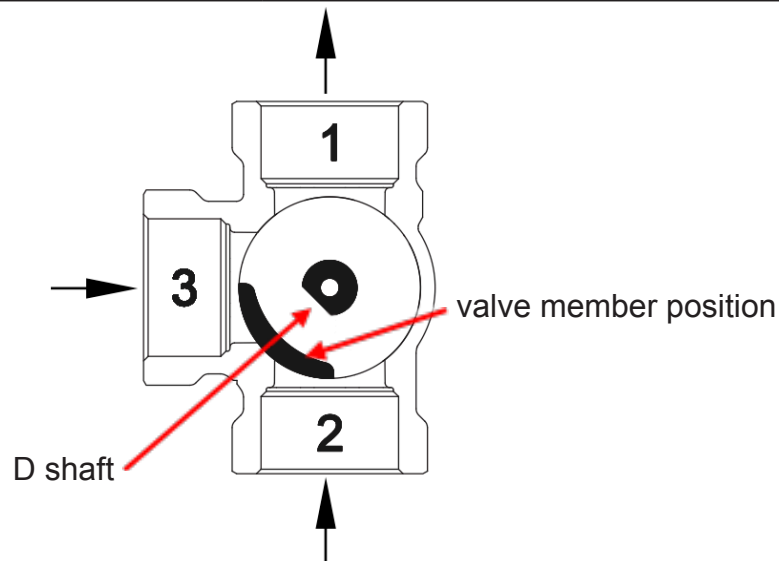

1. When fitting the actuator, turn the D-shaft in such a manner that the valve member is between inlets 2 and 3.

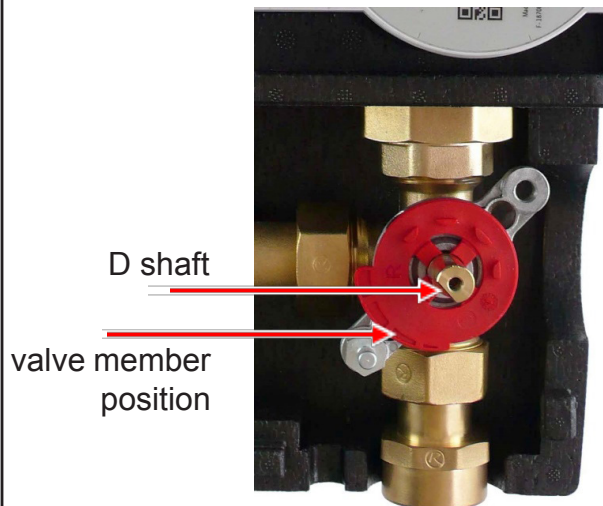

2. Fit the plastic adapter on the shaft. The flat edge of the shaft and the arrow on the plastic adapter are located on the same side as the valve member.



3.
Prior to fitting the actuator on the plastic adapter, switch it to manual control, set the control knob exactly to the middle of its movement range.

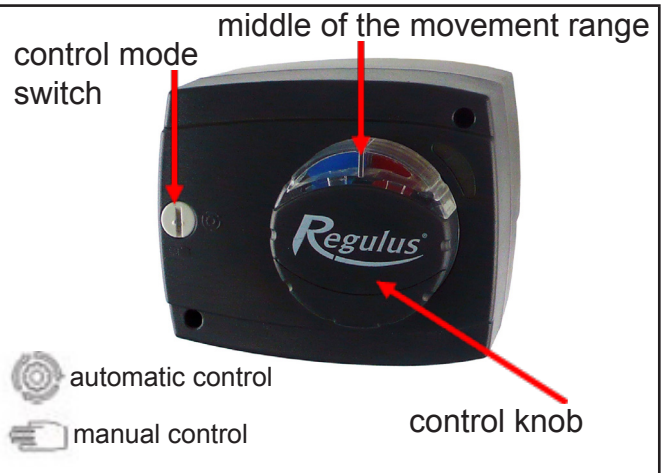

4.
Fit the actuator onto the plastic adapter. Check its turning: the control knob shall be able to turn freely both to left and right by 45° (when turned to the right by 45° the path 3 is closed, and when turned to the left by 45° the path 2 is closed). Having performed the check, tighten the fastening screw and switch back to automatic control.

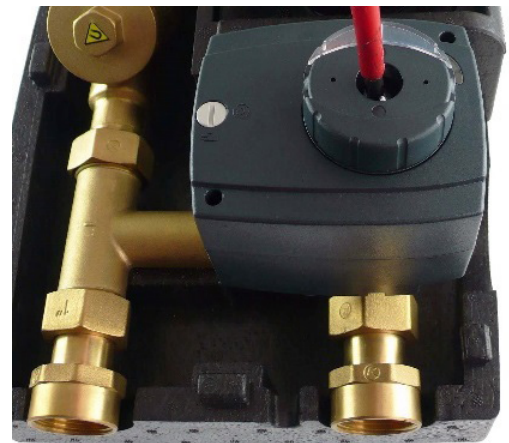

5.
The actuator shall be installed in the same manner as in the figure.



