

# > JOLLY TOP - I

## Fan coil with brushless DC motor



VM (cased)



VN (uncased)

### INTRODUCTION

New series of fan coils with centrifugal fan with high efficiency brushless DC motor. Characterized by a maximum depth of 200 mm with a particularly appealing aesthetic line, they are suitable for residential heating and air conditioning applications. Available in 5 sizes with cooling capacities from **1,50 to 5,60 kW** and air flow rates from **255 to 1190 m<sup>3</sup>/h**. additional rank.

Available in two versions, **VM** with casing and **VN** without casing for recessed applications. The units can be installed both vertically and horizontally.

### AVAILABLE VERSIONS AND INSTALLATION METHODS

The range of centrifugal fan coils has two versions, each of them is available in different capacities.

#### Version

##### VM - Fan coil unit with bottom suction cabinet

Composed of, a sheet metal cover cabinet, a delivery grille with cover to access to the control panel, in thermoplastic material and a regenerable air filter, placed on a metal frame housed on guides made in the lower part of the frame.

##### VN - Fan coil unit without cabinet for built-in applications

Without cover cabinet with regenerable filter, on metal frame.

It can be configured with a series of accessories for the various installation solutions, such as flanges, fittings and grids described in Section ACCESSORIES

### UNIT SPECIFICATIONS

#### ■ BEARING STRUCTURE:

It is made of galvanized sheet metal of adequate thickness. In the back there are slots for fixing the appliance. For models without cover cabinet, a front panel for closing the fan unit is provided.

#### ■ HEAT EXCHANGE BATTERY:

3-row coil in copper tube and aluminum finning blocked by mechanical expansion of the tubes. The manifolds in the upper part of the coil are equipped with air vents, while those in the lower part have holes for draining the water.

#### ■ CONDENSATE COLLECTION TRAY:

Made of thermoplastic material to avoid corrosion phenomena, it allows the installation of the machine both vertically and horizontally. In particular, in the horizontal installation its shape allows to collect the drops of condensation that form on the collectors during cold operation. The drain hole is obtained directly from the condensate collection tray and allows it to be eliminated during cold operation. It is present on both sides of the machine to facilitate coil rotation.

#### ■ FAN MOTOR:

The electric motor is a DC brushless mouse with continuous speed regulation with high efficiency and is directly coupled to the fans and cushioned by elastic supports.

#### ■ CENTRIFUGAL FAN:

The fan unit consists of double suction centrifugal fans with blades developed in length to obtain high flow rates with a reduced number of revolutions.

#### ■ AIR FILTER:

Easily removable and regenerable by simple washing with water.

#### ■ COVER CABINET (VM only):

Made partly of steel sheet painted with epoxy powders to guarantee high resistance to corrosion, and partly of thermoplastic anti-UV material to guarantee resistance to ultraviolet rays.

The grids for air diffusion and the flap to access the control panel are inserted in the upper part, both in UV-resistant thermoplastic material.

Available in RAL 9003.

#### ■ HYDRAULIC CONNECTIONS:

The connections, located on the left side, are female type. It is possible to rotate the battery, which is normally supplied with connections on the left side, in order to move connections to the right side.

TECHNICAL DATA

		Size		150	250	350	500	700
	Power Supply	Fan speed setting	[V-ph-Hz]	230-1-50				
Water: IN 7° - OUT 12°C Ambient Air: 27°C D.B. 19°C W.B.	Total Cooling Capacity	max.	[kW]	1,50	2,35	3,50	4,30	5,60
		med.	[kW]	1,06	1,94	2,89	3,48	4,47
		min	[kW]	0,92	1,19	2,22	2,71	3,14
	Sensible cooling capacity	max.	[kW]	1,14	1,79	2,65	3,25	4,62
		med.	[kW]	0,77	1,44	2,14	2,56	3,6
		min	[kW]	0,66	0,86	1,57	1,91	2,43
	Water flow in cooling	max.	[l/h]	258	404	602	740	963
		med.	[l/h]	182	334	497	599	769
		min	[l/h]	158	205	382	466	540
Water pressure drop in cooling	max.	[kPa]	14	13	34	54	51	
	med.	[kPa]	8	10	25	36	33	
	min	[kPa]	6	5	15	23	18	
Water: IN 45° - OUT 40°C Ambient Air: 20°C	Heating Capacity	max.	[kW]	1,57	2,60	3,80	4,70	6,00
		med.	[kW]	1,07	2,11	3,10	3,70	4,77
		min	[kW]	0,92	1,34	2,35	2,81	3,36
	Water flow in Heating	max.	[l/h]	270	447	654	808	1032
		med.	[l/h]	184	363	533	636	820
		min	[l/h]	158	230	404	483	578
	Water pressure drop in heating	max.	[kPa]	15	14	35	54	55
		med.	[kPa]	8	10	24	37	38
		min	[kPa]	6	5	15	22	19
Water: IN 65° - OUT 55°C Ambient Air: 20°C	Heating Capacity Additional Heat Exchanger	max.	[kW]	1,40	2,30	2,88	3,35	4,60
		med.	[kW]	1,23	1,78	2,49	2,88	3,95
		min	[kW]	0,95	1,22	2,00	2,36	3,02
	Water flow additional Heat Exchanger	max.	[l/h]	120	200	250	290	390
		med.	[l/h]	110	150	210	250	340
		min	[l/h]	80	100	170	200	260
	Water pressure drop additional Heat Exchanger	max.	[kPa]	11	28	55	70	132
		med.	[kPa]	9	18	43	55	104
		min	[kPa]	5	10	29	38	64
General data	Air volume flow	max.	[m³/h]	255	400	595	790	1190
		med.	[m³/h]	170	315	470	580	855
		min	[m³/h]	150	190	340	410	505
	Air flows with only main coil forstatic pressure available 0/12/30 Pa	max.	[m³/h]	333/280/146	489/392/32	683/570/261	893/812/656	1350/1258/1091
		med.	[m³/h]	276/210/43	345/128/24	538/367/31	666/552/237	1029/899/630
		min	[m³/h]	192/77/24	232/19/19	397/197/25	475/258/28	677/451/31
	Air flow rates with main and auxiliary batteries forstatic pressure available 0/12/30 Pa	max.	[m³/h]	318/264/131	465/373/47	641/527/258	845/764/606	1198/1112/949
		med.	[m³/h]	265/198/31	327/164/25	508/339/31	631/516/229	897/774/554
		min	[m³/h]	186/76/24	222/20/20	357/95/24	452/251/228	574/386/32
	Fan power input	max.	[W]	15	17	26	50	96
		med.	[W]	9	12	17	25	44
		min	[W]	8	7	10	14	17
	Maximum rated current	max.	[A]	0,18	0,20	0,26	0,49	0,85
	Sound power	max.	[dB(A)]	47	43	52	59	64
		med.	[dB(A)]	36	37	44	51	56
		min	[dB(A)]	34	29	36	43	45
	Sound pressure (measured at a distance of 1m in a reverbering chamber)	max.	[dB(A)]	34	29	38	46	50
		med.	[dB(A)]	24	24	32	38	42
		min	[dB(A)]	21	18	23	30	31
	Fan motor type		type	DC brushless				
	Fan type		type	Centrifugal fan				
	No. of fans		N°	1	2	2	2	3
	Maximum operating pressure		bar	16				
	Main battery water content 3R		l	0,46	0,68	0,90	0,90	1,02
	Auxiliary coil water content 1R		l	0,15	0,23	0,30	0,30	0,34
	Water connection main coils 3R	F	[ " ]	3/4" G	3/4" G	3/4" G	3/4" G	3/4" G
	Water connection auxiliary coils 1R	F	[ " ]	1/2" G	1/2" G	3/4 1/2" G" G	1/2" G 3/4" G	1/2" G
	Condensate discharge connection O.D.		mm	18,5				
	VM version CASED	Gross weight	kg	23,5	27,5	32,5	32,5	36
		Net weight	kg	18	21,5	25,5	25,5	28,5
Unit size (W x H x D)		mm	495 x 200 x 790	495 x 200 x 1020	495 x 200 x 1240	495 x 200 x 1240	495 x 200 x 1360	
Carton box size (W x H x D)		mm	595 x 300 x 895	595 x 300 x 1125	595 x 300 x 1345	595 x 300 x 1345	595 x 300 x 1465	
VN version UNCASED	Gross weight	kg	19,5	22,5	26,5	26,5	29,5	
	Net weight	kg	14	16,5	19,5	19,5	22	
	Unit size (W x H x D)	mm	455 x 200 x 637	455 x 200 x 867	455 x 200 x 1087	455 x 200 x 1087	455 x 200 x 1207	
	Carton box size (W x H x D)	mm	595 x 300 x 895	595 x 300 x 1125	595 x 300 x 1345	595 x 300 x 1345	595 x 300 x 1465	

**DIMENSION**

**VM version**

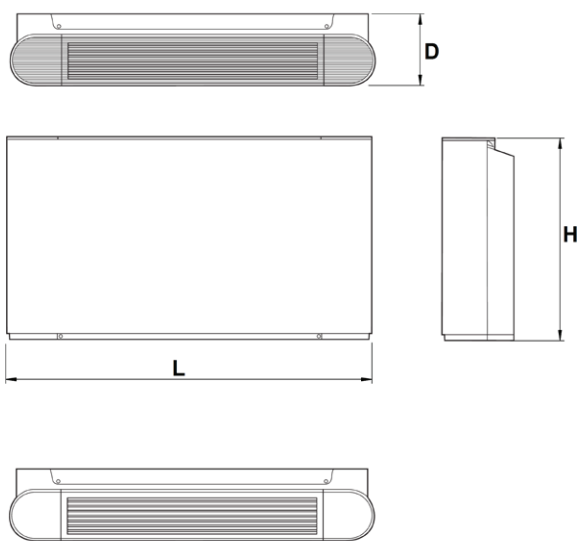

Mod.	150-I	250-I	350-I	500-I	700-I	U.M
L	790	1020	1240		1360	mm
H	495					mm
D	200					mm

**VN version**

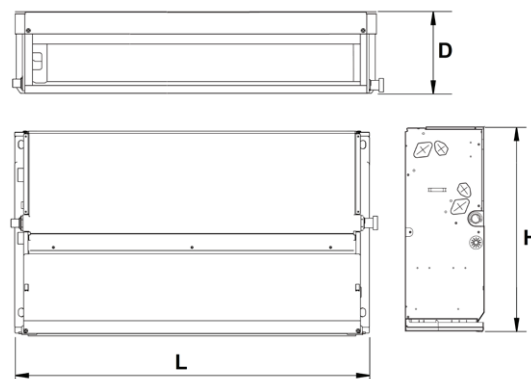

Mod.	150-I	250-I	350-I	500-I	700-I	U.M
L	628	858	1078		1198	mm
H	455					mm
D	200					mm

**ACCESSORIES**

The unit can be equipped with a wide range of accessories designed for different purposes Installation - Plumbing - Room control. The table below describes the possible combinations.

Accessory Description	image	Model					Code nr.
		150-I	250-I	350-I	500-I	700-I	
TE / TER - Thermostat with display for installation on the unit or remote on the wall.		X	X	X	X	X	1
GCM09 - Centralised master controller		X	X	X	X	X	1
GC01 - Centralised module		X	X	X	X	X	1
Support feet		X	X	X	X	X	1
Supplementary coil		X					4
			X				
				X	X		
						X	
kit valve main coil		X	X	X	X	X	1
kit valve supplementary coil		X	X	X	X	X	1
Condenser tray		X	X	X	X	X	1

## CONTROLLERS

### TE / TER - Thermostat with display for installation on the unit or remote on the wall.

It allows to:

1. Turn the unit on or off
2. Choose the heating-cooling operating mode
3. Change the setpoint temperature
4. Select the fan speed

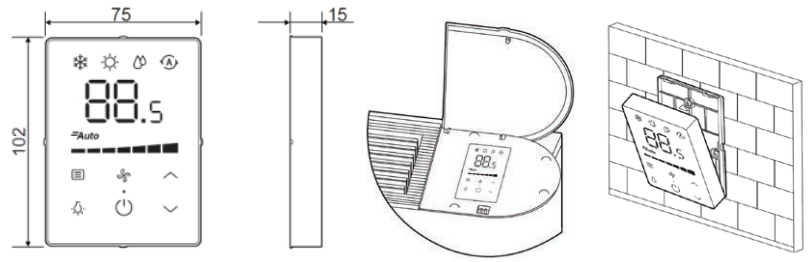

### GC01 - Centralised module

It allows to connect up to 16 fan coils in the serial network which will be controlled as a single group with a single TE / TER thermostat.



### GCM09 - Centralised master controller

The centralized control allows you to connect up to 64 fan coils in the serial network and therefore allows, in groups or individually for all the connected fan coils, to:

1. Turn the unit on or off
2. Choose the heating-cooling operating mode
3. Change the setpoint temperature
4. Select the fan speed
5. Weekly schedule

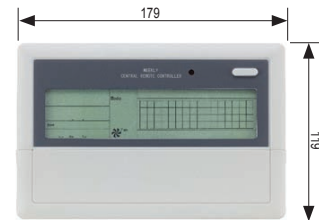

### On-board electronic board

The fancoil unit is supplied with a electronic board that is normally installed on the right side of the fancoil.

It allows to:

1. Control a valve (2-pipe system) or two valves (4-pipe systems)
2. Accept a 0-10V DC input for controlling the DC fan speed
3. Accept a remote on-off input
4. Connect the fancoil unit to a Modbus network
5. Connect the unit to the TE / TER thermostat or to the centralization module GC01 or to the centralized control GC09
6. Call a chiller or a boiler through dry contacts 1A/230 Vac

