

Chillers and Inverter Air/Water heat pumps with axial fans

## Technical Bulletin

### Model

i-32V504

i-32V506

i-32V508,i-32V5SL08

i-32V510

i-32V510T

i-32V512,i-32V5SL12T

i-32V512T,i-32V5SL12T

i-32V514

i-32V514T

i-32V516,i-32V5SL16

i-32V516T,i-32V5SL16T

i-32V518T



This manual has been created for informative purpose. The company declines any responsibility for the results of any projecting or any installation based on the explanations and/or on the technical specifications provided in this manual. It is besides forbidden the reproduction under any form of the texts of the figures contained in this manual. This manual is a translation from the official italian language version. For reasons of environmental respect the Company will not provide the hard copy in the original language which could be directly requested or downloaded from the Company website at any time. In case of any dispute, the original language manual will be the trusted one. Even partial reproduction PROHIBITED © Copyright - Advantix SpA

07	02-2020			Modified description of yield tables, modified description of hydraulic circuit temperature probes, modified part load EER values, added part load cooling capacity, updated data size 4kW, updated data cooling yield tables size 6kW W12, W15, W18, modified recommendations chap. 3.2
06	10-2020			08, 12, 16 kW SL sized version, aligned depth dimensions
05	09-2020			Updated chap. 3.2, 3.3, 4.1 (changed refrigerant charges and SCOP values sizes 04, 16, 16T), added heating performance chap. 9.1, updated SCOP and $\eta_s$ sizes 06, 16, 16T chap. 9.4
04	05-2020			Info deleted ch. 3.2, expansion vessel reference deleted ch. 3.3
03	03-2020			Added Lw values for octave bands, added data for Ta = -15 ° C in heating performance tables, added sizes 10T and 12T
02	09-2019			Correct description 'BMS connectivity ready'.
01	08-2019			Correct heat input (3) nom 18T in data table
00	01-2019			First issue
<b>Rev</b>	<b>Date</b>	<b>Author</b>	<b>Supervisor</b>	<b>Notes</b>
<b>Catalogo / Catalogue / Katalog / Catalogue</b>				<b>Serie / Series / Serie / Serie / Série</b>
<b>BT0110L8500-07</b>				<b>AIR/WATER INVERTER HEAT PUMPS WITH AXIAL FANS</b>

## Contents

1.DESCRPTION OF UNIT AND TECHNICAL SPECIFICATIONS .....	5
1.1 FRAMEWORK .....	5
1.2 COMPRESSORS .....	5
1.3 AIR SIDE HEAT EXCHANGER .....	5
1.4 UTILITY SIDE HEAT EXCHANGER .....	5
1.5 FAN.....	5
1.6 FAN SPEED ADJUSTMENT .....	5
1.7 COOLING CIRCUIT.....	5
1.8 ELETTRIC PANEL.....	7
1.9 CONTROL SYSTEM .....	7
1.10 CONTROL AND PROTECTIVE DEVICES.....	7
1.11 WATER CIRCUIT.....	7
2.DESCRPTION OF VERSIONS AND ACCESSORIES.....	7
2.1 VERSIONS .....	7
2.2 LIST OF ACCESSORIES.....	8
2.3 DESCRIPTION OF ACCESSORIES.....	9
2.3.1 Factory-fitted accessories.....	9
2.3.2 Accessories supplied separately.....	9
3.INSTALLATION .....	11
3.1 UNIT DIMENSIONS, PLUMBING CONNECTIONS AND WEIGHTS .....	11
3.1.1 Net dimensions and with packaging.....	11
3.1.2 Models i-32V5 04/06/08/SL08 .....	11
3.1.3 Models i-32V5 10/10T/12/SL12/12T/SL12T .....	12
3.1.4 Models i-32V5 14/14T/16/SL16/16T/SL16T/18T .....	12
3.1.5 Weights .....	12
3.2 TECHNICAL CLEARANCES.....	13
3.3 WATER CIRCUIT.....	14
3.3.1 Characteristics of the system water.....	15
3.3.2 Typical plumbing diagram .....	15
3.3.3 Plumbing diagram inside unit.....	16
3.3.4 Condensation drain system .....	16
3.3.5 Filling the system.....	17
3.3.6 Draining the system.....	17
4.GENERAL TECHNICAL DATA .....	18
4.1 STANDARD UNIT DATA TABLE .....	18
4.2 SILENCED VERSION DATA TABLE UNIT.....	22
4.3 ELECTRICAL AND AUXILIARY DATA.....	23
5.CORRECTION FACTORS.....	24
5.1 CORRECTION FACTORS FOR USE OF GLYCOL WATER MIXTURE.....	24
5.2 SCALING CORRECTION FACTORS.....	24
5.3 INSTRUMENTATION CALIBRATIONS AND PROTECTIONS.....	24
5.4 CORRECTION FACTORS ACCORDING TO ALTITUDE .....	24
6.HYDRONIC UNIT DATA.....	25
6.1 USEFUL HEADS.....	25

6.2	CHARACTERISTIC CURVES OF CIRCULATORS .....	25
7.	NOISE LEVEL.....	26
8.	OPERATING LIMITS .....	28
8.1	EVAPORATOR WATER FLOW .....	28
8.2	COLD WATER PRODUCTION (SUMMER MODE) .....	28
8.3	HOT WATER PRODUCTION (WINTER MODE).....	28
8.4	AMBIENT AIR TEMPERATURE AND SUMMARY TABLE .....	28
8.5	ENVELOPE IN HEATING AND COOLING.....	29
8.6	ENVELOPE IN DHW .....	29
9.	PERFORMANCE TABLES.....	30
9.1	HEATING STANDARD UNIT VERSION.....	30
9.2	UNIT HEATING SILENCED VERSION.....	32
9.3	COOLING .....	33
9.4	SANITARY.....	34
10.....	DATA FOR THE ENERGY CERTIFICATION OF BUILDINGS ACCORDING TO UNI/TS 11300-4 FOR HEAT PUMPS .....	35
10.1	EER DATA TO CALCULATE THE ENERGY PERFORMANCE OF BUILDINGS, ACCORDING TO UNI/TS 11300-3 .....	46
11.	REFRIGERANT SAFETY DATA SHEET .....	49

## 1. DESCRIPTION OF UNIT AND TECHNICAL SPECIFICATIONS

The i-32V5 heat pumps were designed for residential and commercial applications. They are extremely versatile and designed for heat pump operation with space heating hot water production and for domestic hot water use at a temperature of 60°C. Use of the INVERTER-controlled brushless compressor technology, coupled with electronic expansion valve, pump and variable speed fan optimises consumption and operating efficiency of the chilling components.

### 1.1 FRAMEWORK

All the units of the range are constructed in hot galvanised sheet metal painted with polyurethane powders in kiln at 180°C to assure the best resistance to weathering. The frame is self-supporting with removable panels for easier inspection and maintenance of the inner components. All screws and rivets for outdoor installation are in galvanised steel.

### 1.2 COMPRESSORS

Twin rotary hermetic inverter controlled DC compressors, specifically designed to operate with R32, equipped with thermal protection and mounted on rubber vibration dampers.

The compressors are installed in a compartment separated from the air flow to reduce noise. They are also equipped with crankcase heater to prevent oil dilution which could cause the compressor to seize. This activates if the compressor is off for at least 30 minutes with a discharge temperature lower than 20 °C (with hysteresis of 2.0 °C). The crankcase heater is disabled when the compressor starts back up, as it only runs with the compressor off. The heater also runs with the unit off to prevent re-ignition issues. It is however recommended to power the unit and to put it in standby at least 12 hours before operating it, should the system be completely shut down. The temperature of the oil vessel must be at least 10°C higher than the ambient temperature.

The compressors can be inspected by removing the side and front panels of the unit, so that they can be serviced even with the units running.

### 1.3 AIR SIDE HEAT EXCHANGER

The air heat exchangers are made of copper pipes and aluminium fins. The pipes are mechanically expanded into aluminium fins to increase the thermal exchange factor. The shape of these exchangers allows for low air side pressure drops and therefore fans can run at low speed (thus reducing unit noise). The coils are "GOLD FIN" treated to assure higher resistance to acidity and salty mist. Furthermore, the treatment increases hydrophilic ability and performance compared to a coil with simple aluminium fins.

### 1.4 UTILITY SIDE HEAT EXCHANGER

The utility heat exchangers are the brazed plate type, made of stainless steel AISI 304, insulated at the factory with closed cell material. They can be equipped with anti-freeze electric heater (optional KA accessory). Each evaporator is protected by a temperature probe used as an antifreeze protective probe which, even with the unit off, switches the circulator on if the conditions set on the controller are met.

### 1.5 FAN

The fans are made of plastic, the axial type with airfoil blades. They are all statically and dynamically balanced and are supplied complete with protective grid according to standard IEC EN 60335-2-80 (safety of household and similar electrical appliances). The fans are installed on the unit with rubber vibration dampers applied in between to reduce noise. Only 8-pole modulating brushless electric motors are used (200/1000 rpm). The motors are directly coupled and equipped with built-in thermal protection. The motors all have an IP 44 protection rating.

### 1.6 FAN SPEED ADJUSTMENT

This type of adjustment, managed by the microprocessor, is necessary to optimise evaporation/condensing pressure in summer/winter mode for the correct operation of the unit.

### 1.7 COOLING CIRCUIT

The cooling circuit is made with components of leading international companies and in compliance with UNI EN standard 13134 on brazing procedures. The coolant is the new R32 ecological gas. The basic version of the cooling circuit includes: 4-way cycle reversing valve, electronic expansion valve, liquid separator, maintenance and control inspection valves, safety device (high-pressure switch), pressure transducers to carefully adjust evaporation and condensing pressure, filters to prevent obstructions on the thermal expansion valve.

**Circuit diagram i-32V5 04-06-08-SL08-10-10T-12-SL12-12T-SL12T**

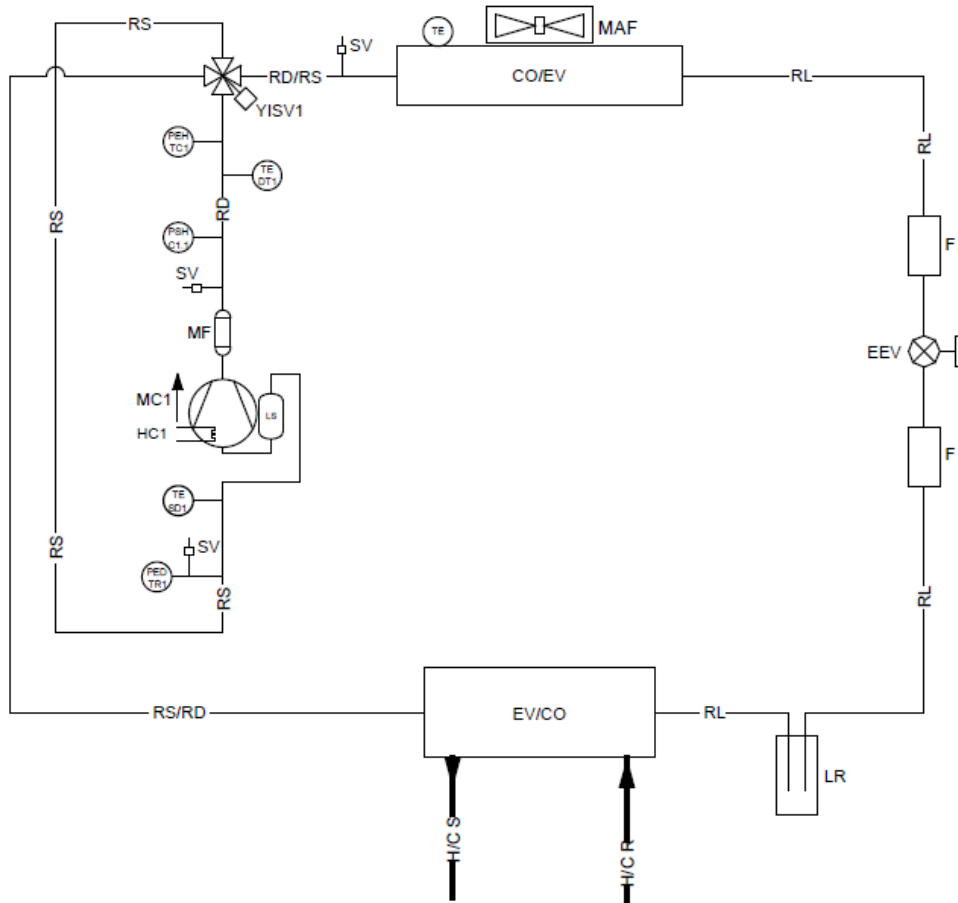

**Circuit diagram i-32V514-14T-16-SL16-16T-SL16T-18T**

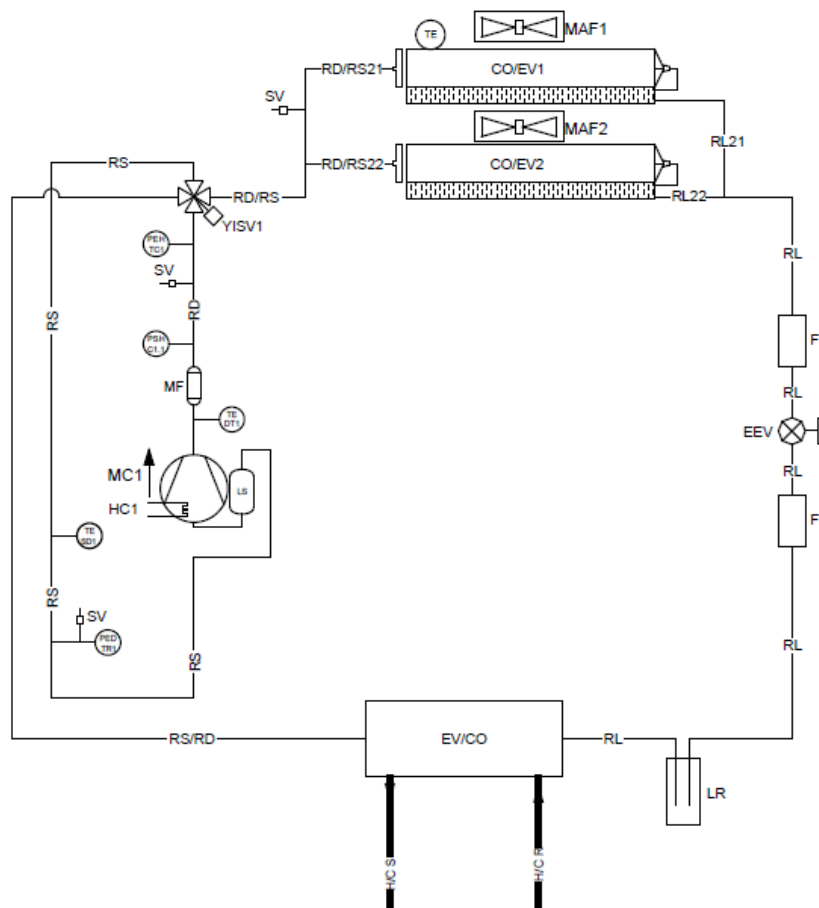

ARTICLE	DESCRIPTION	ARTICLE	DESCRIPTION
MC	COMPRESSOR	RD	DELIVERY LINE
CO/EV	CONDENSER (IN CHILLER MODE)	RL	LIQUID LINE
EV/CO	EVAPORATOR (IN CHILLER MODE)	RD/RS	DELIVERY/INTAKE LINE
EEV	ELECTRONIC EXPANSION VALVE	RS/RD	INTAKE/DELIVERY LINE
YISV	4-WAY CYCLE REVERSING VALVE	H/CS	UTILITY WATER OUTLET
LR	LIQUID RECEIVER	H/CR	UTILITY WATER INLET
F	FILTER	PEH TC	HIGH PRESSURE TRANSDUCER
SV	FILLING CONNECTION	PED TR	LOW PRESSURE TRANSDUCER
HC	CRANKCASE HEATER	TE	OUTDOOR AIR TEMPERATURE PROBE
MAF	AXIAL FAN	TE SD	INTAKE LINE TEMPERATURE PROBE
MF	MUFFLER (NOT PRESET IN i-32V504)	TE DT	COMPRESSOR DISCHARGE TEMPERATURE PROBE
LS	LIQUID SEPARATOR	PSH C	AUTOMATIC RESET HIGH-PRESSURE SWITCH
RS	INTAKE LINE		

## 1.8 ELETTRIC PANEL

The electric panel is built in compliance with current European standards. The electric panel can be accessed by removing the cover on the unit using a specific tool. The electric panel has an IP24 protection rating. The panel is also supplied with terminal block with voltage-free contacts for remote ON-OFF, summer/winter mode switching, auxiliary heater, domestic hot water sensor, external 3-way valve management and contacts for the remote control panel and to manage the double working set-point.

## 1.9 CONTROL SYSTEM

All i-32V5 units are equipped with microprocessor with superheating control logic by means of an electronic thermostatic valve managed according to the signals sent by the pressure transducers. The CPU also controls the following functions: water temperature control, antifreeze protection, compressor timing, alarm reset, alarm management and operating LEDs. The control system, together with the INVERTER technology and onboard sensors, monitors and promptly and continuously adapts the performance of the inverter compressor, of the circulator and of the fan (2 fans in models 14,14T,16,SL16,16T,SL16T e 18T).

## 1.10 CONTROL AND PROTECTIVE DEVICES

All the units are standard supplied with the following control and protective devices: return water temperature probe, installed on water return pipe from the plant, working and antifreeze probe installed on the water delivery pipe to the plant, high pressure transducer, low pressure transducer, inlet and outlet temperature probes from the compressor, compressor thermal protection, fan thermal protection, water side flow switch protecting the evaporator, HP pressure switch.

## 1.11 WATER CIRCUIT

i-32V5 chillers are supplied with a built-in water circuit which includes: modulating circulator with high-efficiency brushless motor (EEI≤0.23 for sizes 14 and 16, SL16 EEI≤0.20 for 06, 08, SL08, 10 and 12, SL12), suitable for the use of chilled water and managed directly by the machine's controller, plate heat exchanger, protective flow switch, safety valve (6 bar) to be connected to a collection system and manual air venting valve.

## 2. DESCRIPTION OF VERSIONS AND ACCESSORIES

### 2.1 VERSIONS

i-32V5 - reversible heat pump with built-in hydronic unit (safety valve, pressure gauge, modulating circulator, flow switch, automatic venting valve, filling/drain valve)

Available models: 04,06,08,SL08,10,10T,12,SL12,12T,SL12T,14,14T,16,SL16,16T,SL16T,18T. Sizes 10,12,14 and 16 are available both single phase and three-phase. The other sizes only have single phase power supply.

The code of the unit is composed of:

- 7 fixed digits
- the symbol # as separator
- 7 variable digits (fields) identifying the sizes, power supply and factory mounted accessories
- 2 variable digits (MC field) which identify the i-32V5 series in any customisations

0110419#{VR}{AE}{CT1}{KA}{CR}{AC1}{MC}

ORDER CODE	UNIT VERSION		POWER SUPPLY		THERMAL CAPACITY		ANTIFREEZE KIT		REMOTE CONTROL		ACCESSORY 1	
0110419#	VR		AE		CT1		KA		CR		AC1	
	2	Standard										
	3	Standard with GI										
	6	SL version										
	7	SL version + GI										
	0	Single-phase										
	1	Three-phase										
	22	04 kW (*) (***)										
	16	06 kW (*) (***)										
	17	08 kW (*)										
	18	10 kW (*) (***)										
	19	12 kW (*)										
	20	14 kW (***)										
	21	16 kW										
	23	18 kW (**) (***)										
0	Without antifreeze kit	0	No one									
1	With antifreeze kit	2	Modbus protocol									
0	No one											
T	Battery treatment											

(\*) Variants not valid for AE=1

(\*\*) Variants not valid for AE=0

(\*\*\*) Variants not valid for VR=6 o VR=7



**CAUTION: The antifreeze kit is a factory mounted accessory. It cannot be installed at a later time.**

## 2.2 LIST OF ACCESSORIES

The available accessories for the i-32V5 heat pumps are listed below

	Accessory	Standard	Factory-fitted	Supplid separately
Vibration damper kit	x			x
Antifreeze kit	x		x	
Coil anticorrosion treatment	x		x	
VDIS2 - Diverter valve (1"1/4) Kvs 19.2	x			x
Electronic throttling valve		x	x	
Antifreeze thermal drain valve	x			x
SAS - Domestic hot water probe / System remote probe	x			x
Flow switch (flow presence signal)		x	x	
Axial fan with BLDC motor		x	x	
Hi-T2 - Multi-purpose touch screen remote control	x			x
Fancoil control (Hi-T control required)	x			x
i-CR - Wall remote controller	x			x
GI - Plant management module	x		x	
Phase monitor (only three-phase power supply unit)		x	x	
Remote on/off voltage-free contact		x	x	
BMS connectivity arrangement - ModBus protocol included (CM)		x	x	
USB/RS485 serial converter (ISK)	x			x

	Accessory	Standard	Factory-fitted	Supplid separately
Editing the set-point from 0-10V input		x	x	
Editing the dynamic set-point - climate curve (via external air probe fitted in the unit)		x	x	
Voltage-free contact for Summer/Winter selection		x	x	
Digital input for double set-point *		x	x	
DHW request digital input *		x	x	

\*Functions can be enabled as an alternative

## 2.3 DESCRIPTION OF ACCESSORIES

### 2.3.1 Factory-fitted accessories

**Antifreeze kit** - It makes use of a self heating cable which is wound around the base of the external unit near the condensing coil and two heaters placed on the sides of the plate heat exchanger.

**Coil anticorrosion treatment** - thanks to this treatment the coil becomes flexible to withstand thermal contractions and expansions, it is mechanically resistant, protected from UV rays and dirt repellent. Heat transmission losses are very low (around 2%). The treatment assures coil protection virtually in all environmental conditions: from marine to rural settings, from industrial to urban areas.

**Electronic throttling valve** – expansion valve, designed for the control and continuous regulation of the amount of refrigerant fed into the evaporator. Changes in thermal load may be followed quickly, so as to achieve optimised consumption.

**Flow switch (flow presence signal)** – this device monitors and signals water circulation in the plate heat exchanger. This component is essential because it switches off and secures the unit preventing the formation of ice.

**Axial fan with BLDC motor** – Brushless modulating 8 poles (200/1000 RPM), built-in condensation/evaporation control.

**GI - System management module** – to manage the following functions:

- Booster circulator management with the aid of a room thermostat (not supplied);
- Management of a plant side mixer valve both in heating and cooling mode;
- Solar–thermal integration management.

**Phase monitor (only three-phase power supply unit)** – Three-phase relay to signal incorrect phase sequence, total and partial missing phase.

**Remote on/off voltage-free contact** – contact in the terminal block to enable the unit's switching on and off

**BMS connectivity arrangement - ModBus protocol included (CM)** - accessory to connect the unit to external controllers via serial cable with RS-485 electric standard and ModBus RTU protocol.

**Editing the set-point from 0-10V input** – this adjustment allows you to edit the set-point by adding (or subtracting) a value depending on the 0-10V input (if enabled).

**Editing the dynamic set-point - climate curve (via external air probe fitted in the unit) Dynamic set-point modification** – the regulator allows you to modify the set-point by adding a value according to the temperature of the outdoor air probe.

**Voltage-free contact for Summer/Winter selection** – option of remotely controlling the heating or cooling mode of the heat pump.

**Digital input for double set-point** - input to change the set point

**DHW request digital input** - function which can be activated as an alternative to managing the double setpoint. The domestic hot water function can be enabled by closing/opening a digital input of the unit. This function is recommended in the event of using two or more heat pumps in cascade hydraulically connected to the same DHW storage tank.

### 2.3.2 Accessories supplied separately

**Vibration damper kit** – they prevent transmitting vibrations to the structure; they must be fitted into the appropriate holes underneath the unit.

**VDIS2 - Diverter valve (1"1/4)** VDIS2 - DN motorised 3-way ball valve (1"1/4) Kvs 19,2, connections FFF 1" ½ FFF G complete with servo-control.

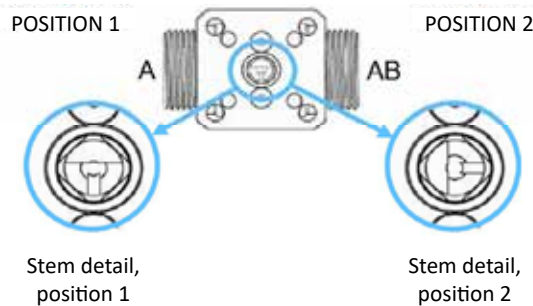
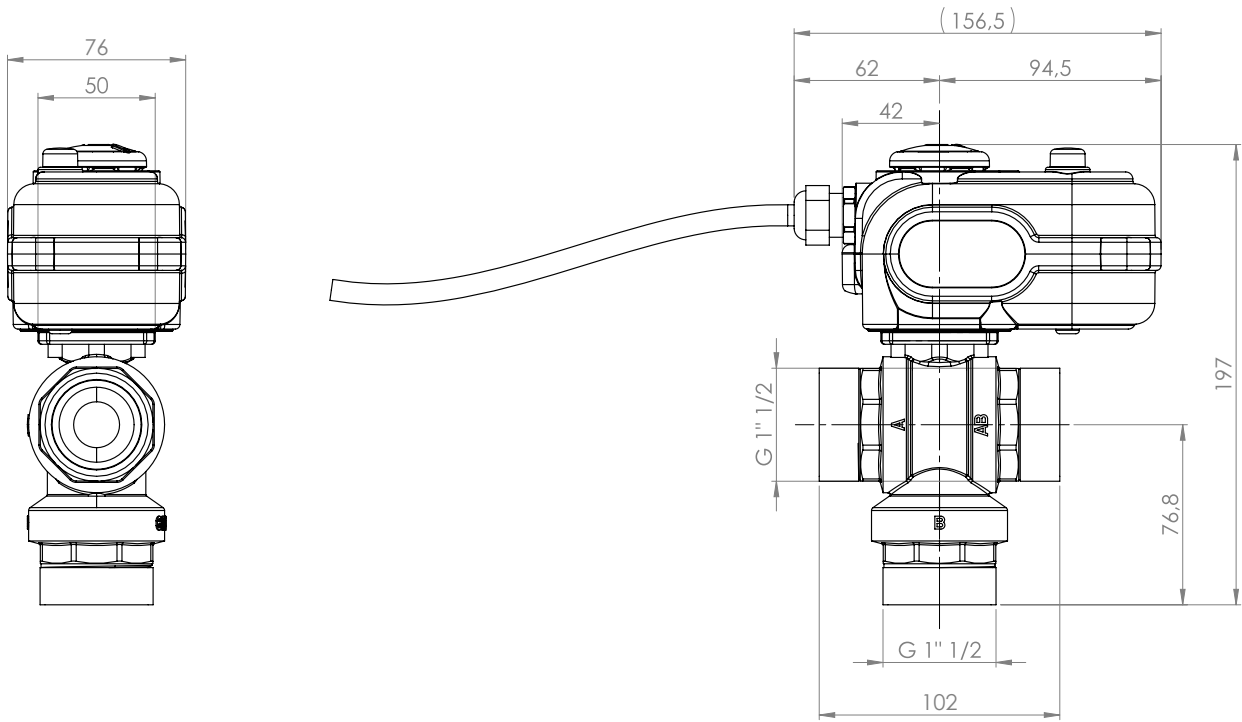

POSITION 1 = OPEN B-A  
POSITION 2 = OPEN B-AB

Permitted substances:  
 water between -15°C and +110°C  
 Below 0° only for water with added antifreeze  
 Not suitable for group 1 and 2 gas, group 1 liquids (Directive 2014/68/EU)  
 Characteristics of actuator without spring return:  
 Force [Nm]: 16  
 Stroke time: 60 s  
 Power supply 230 Vac  
 IP rating: 65  
 Valve body specifications:  
 Frame: PN 40

**Antifreeze thermal drain valve** – valve able to open at 0°C to prevent the formation of ice inside the pipes.

**SAS - Domestic hot water probe / System remote probe** – In some engineering solutions (e.g. heat pump in parallel to boiler on same hydronic circuit and shut off diverter valve) it might be necessary to enable a system temperature probe so that the machine controller can correctly process the control. The plant remote probe controls the temperature of the heat pump only during the compressor start-up phase. Shutdown is managed by the probe on the heat pump delivery line.

**Hi-T2 - Multi-purpose touch screen remote control** – touch screen remote control for centralised management of a chiller/heat pump network. It includes humidity and temperature sensors for the thermal hygrometric analysis of the environment and for the management of the double set point for radiant floor heating systems that use a dehumidification system.

**Fancoil control (Hi-T control required)** – microprocessor device designed to regulate heating/cooling systems with 2 or 4 pipe fan coils, in systems with Hi-T2 remote control and air/water chillers/heat pumps.

**i-CR - Wall remote controller** – Modbus remote control panel with negative LCD and capacitive buttons. The device must be used as a remote keypad for the machine, it has local temperature detection and reproduces the functions of the machine's control panel.

**USB/RS485 serial converter (ISK)** – interface device able to read and write the control logs via the RS485 standard and convert it into a USB port that can be connected to any supervision system.

### 3. INSTALLATION

All the handling, installation and maintenance operations must only be carried out by QUALIFIED PERSONNEL. Before any operation on the unit, make sure that power is disconnected.  
The minimum temperature allowed for storing the units is 5°C.

#### 3.1 UNIT DIMENSIONS, PLUMBING CONNECTIONS AND WEIGHTS

##### 3.1.1 Net dimensions and with packaging

Model i-32V5	Length [mm]	Width [mm]	Height [mm]	Plumbing connections IN/OUT	Dimensions with packaging (length X width X height) [mm]
04-06-08-SL08	924	379	828	1" M	970 x 395 x 985
10-10T-12-SL12-12T-SL12T	1047	466	936	1" M	1080 x 510 x 1130
14-14T-16-SL16-16T-SL16T-18T	1044	455	1409	1" M	1100 x 490 x 1605

##### 3.1.2 Models i-32V5 04/06/08/SL08

IN/OUT: 1" M G

E: power supply input

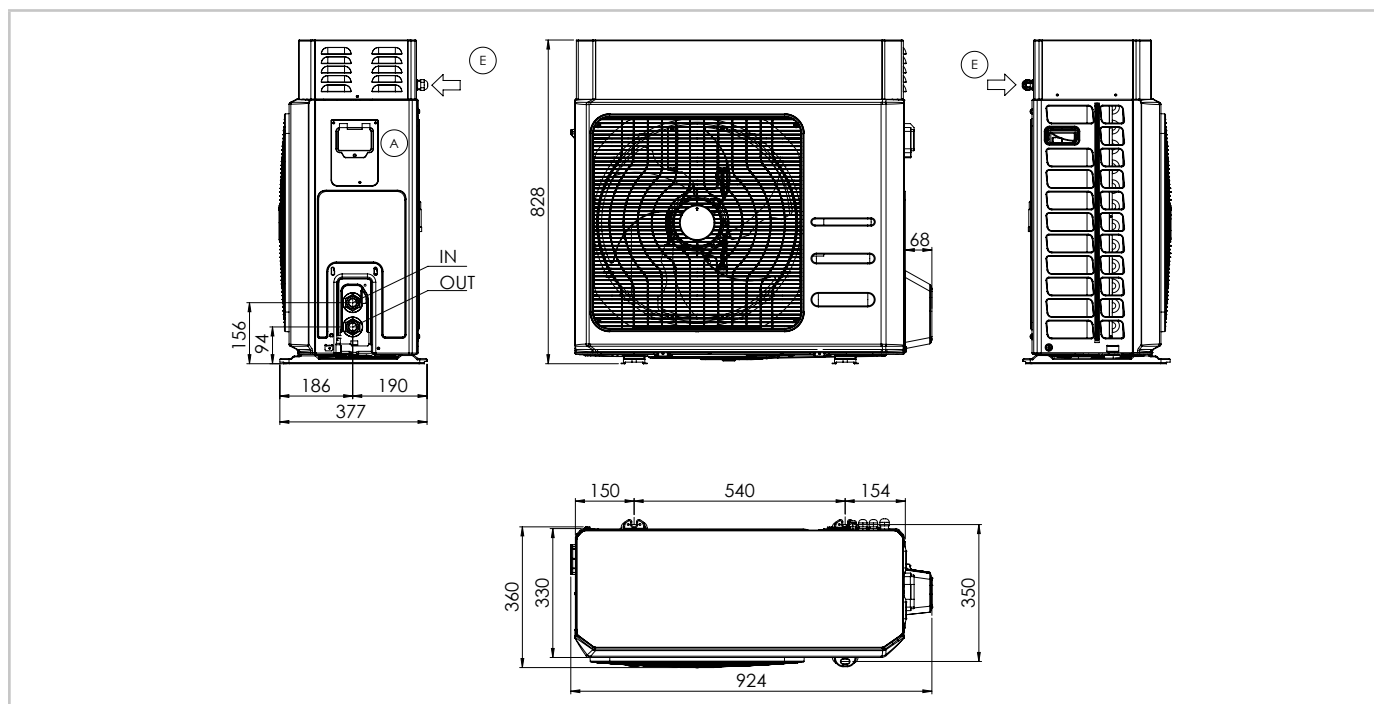

### 3.1.3 Models i-32V5 10/10T/12/SL12/12T/SL12T

IN/OUT: 1" M G

E: power supply input

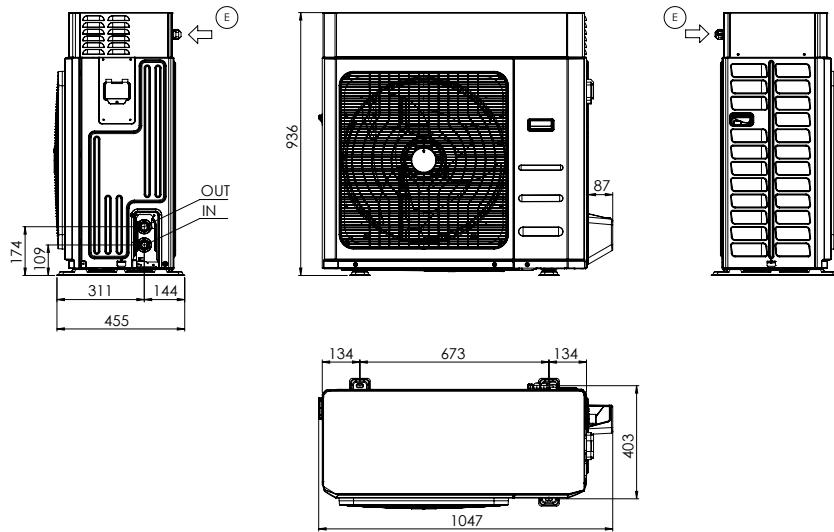

### 3.1.4 Models i-32V5 14/14T/16/SL16/16T/SL16T/18T

IN/OUT: 1" M G

E: power supply input

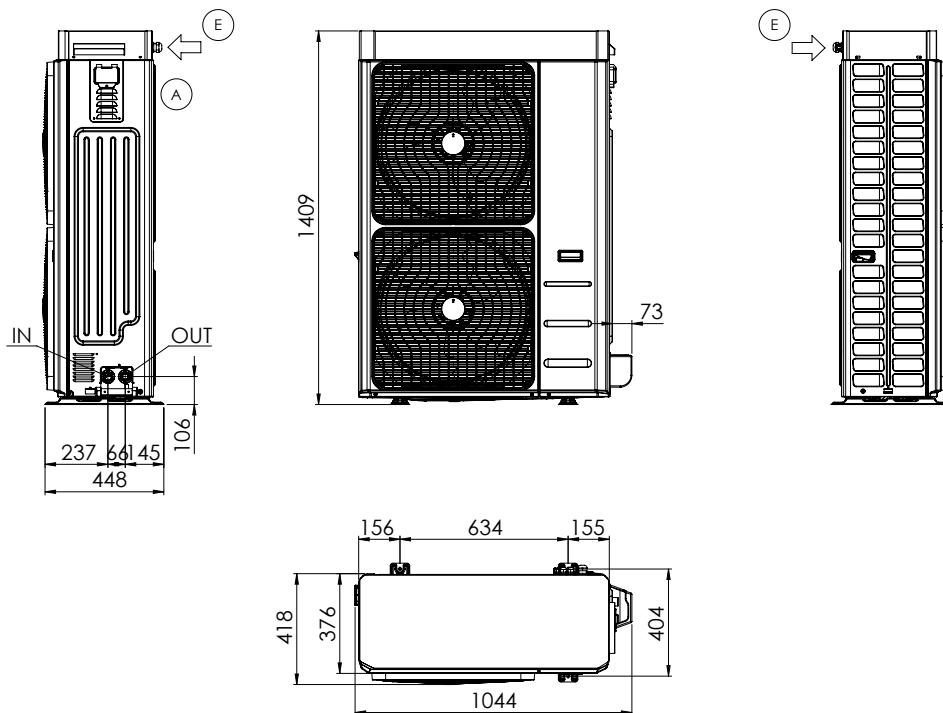

### 3.1.5 Weights

Model i-32V5	Shipping weight [kg]	Operating weights [kg]
i-32V504	73	61
i-32V506	84	72
i-32V508,i-32V5SL08	84	72
i-32V510	110	96
i-32V510T	122	108
i-32V512,i-32V5SL12	110	96
i-32V512T,i-32V5SL12T	122	108
i-32V514	134	121
i-32V514T	148	136

Model i-32V5	Shipping weight [kg]	Operating weights [kg]
i-32V516,i-32V5SL16	140	126
i-32V516T,i-32V5SL16T	154	141
i-32V518T	154	141

### 3.2 TECHNICAL CLEARANCES

The whole range is designed and constructed for outdoor installations.

It is advisable to create an adequately sized support base for the unit. The units transmit a small amount of vibrations to the ground: it is nonetheless advisable to apply vibration dampers between the base frame and support surface.

**In the case of hanging installation it is necessary to ensure that the wall is made of solid bricks, concrete or materials with similar resistance characteristics. The load-bearing capacity of the wall must be sufficient to support at least four times the weight of the unit.**

**The support surface must have a sufficient load-bearing capacity to support the weight of the unit, which can be seen both on the technical label affixed to the machine and in this manual in the "Technical Data" chapter.**

**The supporting surface must not be inclined to ensure correct operation of the unit and to prevent it from tipping over.**

**The installation surface of the unit must not be smooth, in order to avoid the deposit of water/ice, a potential source of danger.**

**The installation location of the unit must be free from foliage, dust, etc., which could clog or cover the batteries.**

**Installation in areas subject to stagnation or falling water, e.g. from gutters, should be avoided.**

**Also, avoid locations that are subject to snow accumulation (such as corners of buildings with sloping roofs). When installing in areas subject to snowfall, install the unit on a base that is raised 20-30 cm above the ground to prevent snow from accumulating around the unit.**

**It is recommended to ensure sufficient air exchange to dilute the R32 gas in case of accidental leakage, thus avoiding the formation of explosive atmospheres. For this reason, a minimum distance of 1 meter must be maintained from openings or wells, in which the gas could accumulate.**

**Installation of the unit under roofs of any kind, such as roofs, canopies and the like, should be avoided.**

It is very important to avoid recirculation between intake and delivery air, so as not to downgrade performance of the unit or even to interrupt its normal operation. This is why the minimum clearances shown below must be guaranteed.

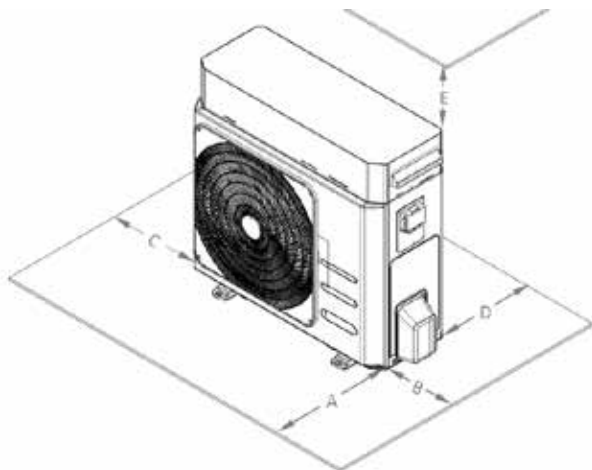

MODEL		A	B	C	D	E
<b>i-32V504</b>	mm	1500	500	400	400	500
<b>i-32V506</b>	mm	1500	500	400	400	500
<b>i-32V508, i-32V5SL08</b>		1500	500	400	400	500
<b>i-32V510/i-32V510T</b>		1500	500	400	400	500
<b>i-32V512, i-32V5SL12/ i-32V512T, i-32V5SL12T</b>		1500	500	400	400	500
<b>i-32V514/i-32V514T</b>		1500	500	400	400	500
<b>i-32V516, i-32V5SL16/ i-32V516T, i-32V5SL16T</b>		1500	500	400	400	500
<b>i-32V518T</b>		1500	500	400	400	500

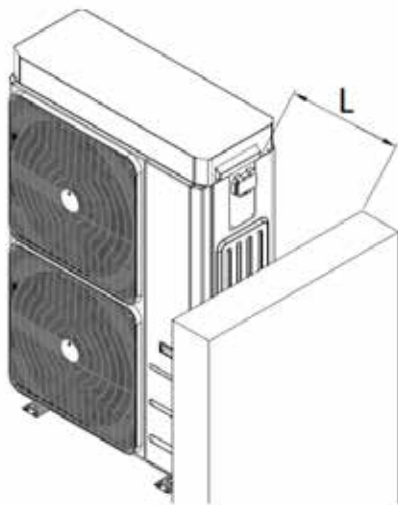

MODEL	L [mm]
i-32V504	500
i-32V506	500
i-32V508, i-32V5SL08	500
i-32V510/i-32V510T	500
i-32V512, i-32V5SL12/ i-32V512T, i-32V5SL12T	500
i-32V514/i-32V514T	500
i-32V516, i-32V5SL16/ i-32V516T, i-32V5SL16T	500
i-32V518T	500

**Do not obstruct or cover the vents on the top cover.**

**For installations in locations with strong winds, refer to the area classification according to the Beaufort scale. If the value is  $\geq 7$  (strong wind, average wind speed = 13.9-17.1 m/s) it is strictly necessary to keep the fan powered at all times, in order to prevent its involuntary rotation.**

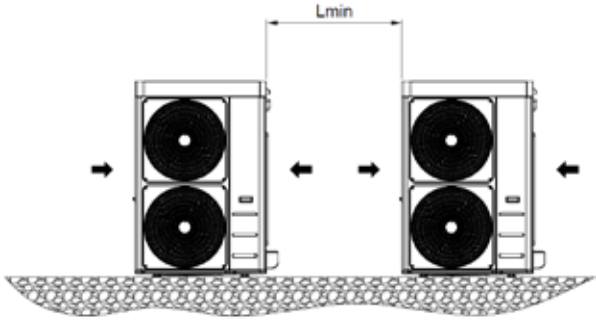
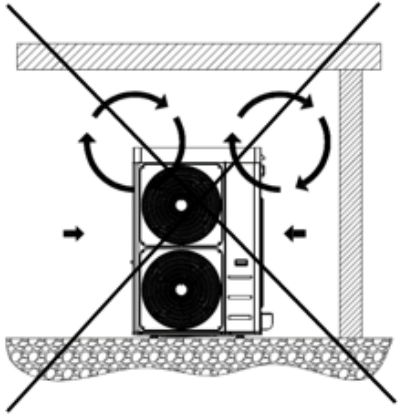
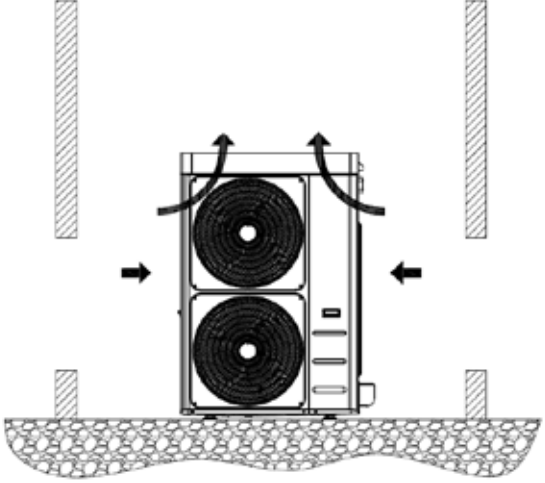
<p>In the event of side-by-side units, the minimum Lmin distance between them is 1 m.</p>	
<p>Covering with canopies or placing near plants or walls should be avoided to prevent air recirculation.</p>	
<p>In the event of winds stronger than 2.2 m/s the use of wind barriers is recommended.</p>	

It is always advisable to make an environmental impact assessment based on the power and sound pressure data given in the "Technical data" chapter and the sound emission limits based on the area where the unit is installed, with reference to the DPCM of 14/11/1997. An assessment must also be made if the unit is installed in the vicinity of workers, according to D. LGS. 81/2008 Art. 189 and following. In order to reduce vibrations and noise, we recommend the use of rubber seals for wall installation.

### 3.3 WATER CIRCUIT

The plumbing connections must be done in accordance with national and/or local regulations; pipes can be made of steel, galvanised steel or PVC. Pipes must be accurately sized according to the nominal water flow rate of the unit and the pressure drops of the water circuit. All pipes must be insulated with closed-cell material of adequate thickness. The chiller must be connected to the pipes using flexible joints. The water circuit should include the following components:

- Well thermometers to monitor the circuit's temperature
- Manual gate valves to isolate the chiller from the water circuit.
- Metal Y filter (installed on the return pipe) with metal mesh no larger than 1 mm.
- Loading group and exhaust valve where necessary.

- Correctly sized expansion vessel.



**ATTENTION: CAUTION:** when sizing the pipes, make sure not to exceed the maximum pressure drop on plant side reported in the technical data table (see useful head).

**CAUTION:** connect the pipes to their fittings always using the key to key method.

**ATTENTION:** make a correct discharge for secure valve.

**ATTENTION:** It is the installer's responsibility to check that the expansion tank is adequate for the actual capacity of the system.

**CAUTION:** The return pipe from the system must be installed near the label "WATER INLET" otherwise the evaporator could freeze.

**CAUTION:** It is mandatory to install a metal filter (with mesh no larger than 1 mm) and a dirt separator on the return pipe from the system labelled "WATER INLET". If the flow switch is manipulated or altered, or if the metal filter and dirt separator are missing, the warranty will terminate immediately. The filter and dirt separator must be kept clean. Therefore, after installing the unit, you must make sure that they are still clean and check them regularly.

All of the units leave the company supplied with flow switch (installed in factory). If the flow switch is altered or removed or if the water filter and dirt separator are missing from the unit, the guarantee will be void. Refer to the wiring diagram attached to the unit to connect the flow switch. Do not bridge never water flow switch connections in the terminals.

The heating system and the safety valves must comply with the requirements of standard EN 12828.

### 3.3.1 Characteristics of the system water

To guarantee correct operation of the unit, the water must be appropriately filtered (see the instructions at the start of this paragraph) and there must be only a minimum amount of dissolved substances. The maximum allowed values are shown below

MAXIMUM CHEMICAL-PHYSICAL PROPERTIES ALLOWED FOR THE CIRCUIT WATER	
PH	7,5 - 9
Electrical conductivity	100 - 500 $\mu$ S/cm
Total hardness	4,5 – 8,5 dH
Temperature	< 65°C
Oxygen content	< 0,1 ppm
Max glycol quantity	40 %
Phosphates (PO4)	< 2ppm
Manganese (Mn)	< 0,05 ppm
Iron (Fe)	< 0,3 ppm
Alkalinity (HCO3)	70 – 300 ppm
Chloride ions (Cl-)	< 50 ppm
Sulphate ions (SO4)	< 50 ppm
Sulphide ions (S)	None
Ammonium ions (NH4)	None
Silica (SiO2)	< 30 ppm

### 3.3.2 Typical plumbing diagram

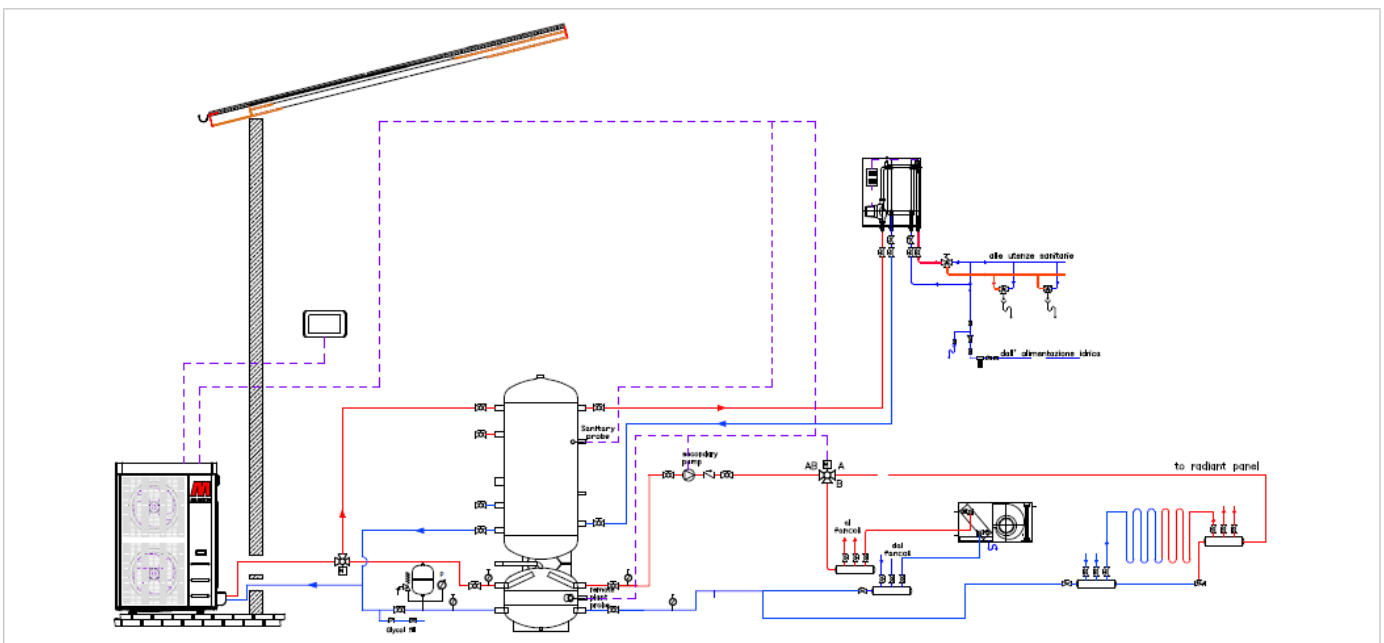

A recommended connection diagram is shown below.

### 3.3.3 Plumbing diagram inside unit

The unit plumbing connection diagrams are provided below.

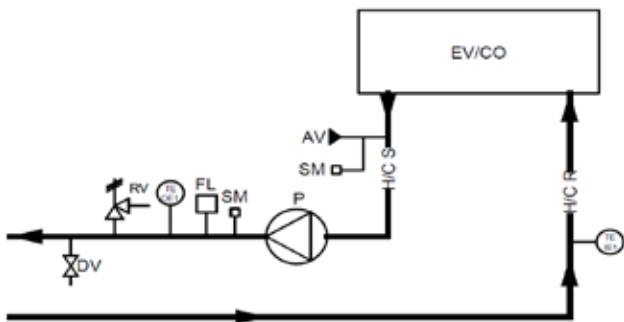

Models i-32V5 04/06/08/SL08

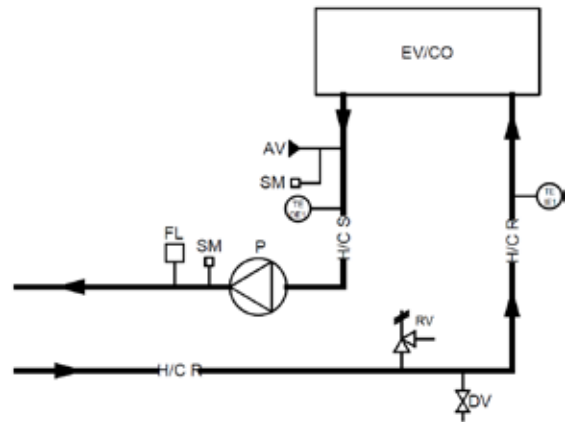

Models i-32V5 10/10T/12/SL12/12T/SL12T

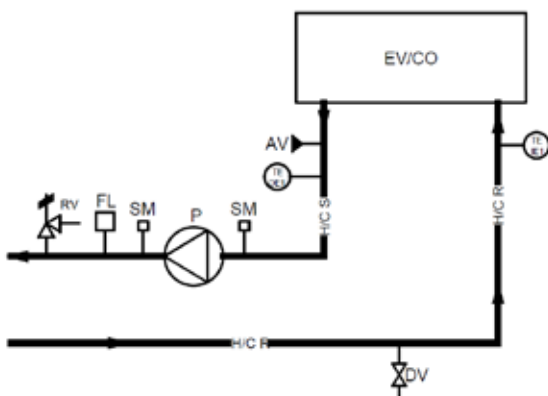

Models i-32V5 14/14T/16/SL16/16T/SL16T/18T

TE IE1	UTILITY INLET TEMPERATURE PROBE
TE OE1	UTILITY OUTLET TEMPERATURE PROBE
DV	DRAIN VALVE
RV	SAFETY VALVE
FL	FLOW SWITCH
P	PUMP
AV	AUTOMATIC AIR VENTING VALVE
SM	SERVICE SLEEVE

### 3.3.4 Condensation drain system

All i-32V5 units are built so that their base works as a condensate drip tray. A plastic fitting is standard supplied to be connected below the base in the appropriate arrangement to connect a pipe which channels the condensate.

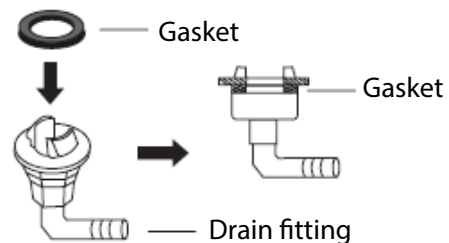
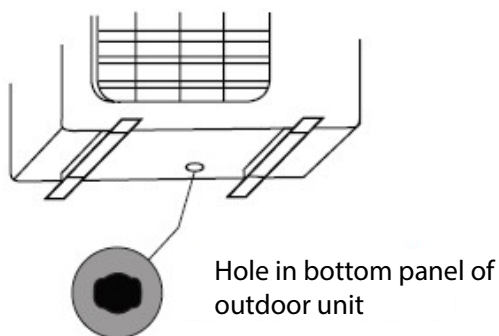

Each unit is therefore fitted with a hole on the base of the hydronic kit (on the coil side) to drain condensation which could drip from the pipes of the plumbing system. Since these pipes are well insulated, a minimum amount of condensation is produced anyway and therefore it is not mandatory to connect a drain pipe to this fitting.

**ESPECIALLY IN VERY COLD CLIMATE REGIONS, IT IS RECOMMENDED TO INSTALL ELEVATION SUPPORTS IN ORDER TO ALLOW ICE FORMATION UNDER THE UNIT WITHOUT DAMAGING IT BY FREEZING.**

### 3.3.5 Filling the system



**CAUTION:** supervise all filling/top-up operations.

**CAUTION:** before filling/topping up the system, disconnect power to the units.

**CAUTION:** the system must always be filled/topped up in controlled pressure conditions (max 1 bar). Make sure that a pressure reducer and safety valve have been installed on the filling/top-up line.

**CAUTION:** the water on the filling/top-up line must be appropriately pre-filtered from any impurities and suspended particles. Make sure that a removable cartridge filter and dirt separator are installed on the line.

**CAUTION:** regularly check and vent the air built up in the system.

**CAUTION:** install an automatic air venting valve at the highest point of the system.

If it is necessary to top up the system or adjust the glycol content, the service tap can be used. Unscrew the cap of the service tap (A) and connect a 14 or 12 mm pipe (internal diameter measurements - check the tap model installed on your unit) to the hose connector connected to the water mains, then fill the system by unscrewing the ring nut (B). After this operation, tighten the ring nut (B) again and screw the cap (A) back on. In any case, it is advisable to use an external tap to fill the system.

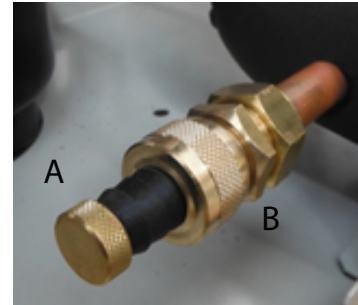

### 3.3.6 Draining the system

If the unit needs to be drained completely, first close the manual inlet and outlet gate valves (not included in supply) and then detach the pipes on the outside of the water inlet and outlet to drain liquid from the unit (to make this operation easier, it is recommended to install two drain valves between the unit and manual gate valves on the outside of the water inlet and outlet).

**4. GENERAL TECHNICAL DATA**

**4.1 STANDARD UNIT DATA TABLE**

TECHNICAL SPECIFICATIONS		Unit	i-32V5			
			04	06	08	10
Cooling	Cooling capacity (1) min/nom/max	kW	2,47 / 4,33 / 4,76*	3,20 / 5,02 / 5,52*	3,80 / 6,08 / 6,69*	4,66 / 7,53 / 8,28*
	Input power (1)	kW	1,37	1,60	1,99	2,39
	E.E.R. (1)	W/W	3,16	3,14	3,05	3,15
	Cooling capacity (2) min/nom/max	kW	3,99 / 5,59 / 6,15*	4,82 / 6,18 / 6,80*	4,91 / 7,72 / 8,49*	6,22 / 9,50 / 10,4*
	Input power (2)	kW	1,12	1,28	1,76	2,15
	E.E.R. (2)	W/W	4,99	4,82	4,38	4,41
	SEER (5)	W/W	3,97	4,12	4,25	4,15
	Water flow rate (1)	L/s	0,21	0,24	0,28	0,36
	User side heat exchanger pressure drops (1)	kPa	1,1	2,0	2,8	6,9
Heating	Heating capacity (3) min/nom/max	kW	3,21 / 4,76 / 5,47*	3,95 / 6,08 / 6,99*	3,95 / 7,81 / 8,98*	5,33 / 10,1 / 11,6*
	Input power (3)	kW	1,00	1,35	1,78	2,28
	C.O.P. (3)	W/W	4,76	4,51	4,38	4,43
	Heating capacity (4) min/nom/max	kW	3,11 / 4,75 / 5,46*	3,82 / 5,88 / 6,76*	3,80 / 7,58 / 8,72*	5,18 / 9,76 / 11,2*
	Input power (4)	kW	1,30	1,66	2,17	2,80
	C.O.P. (4)	W/W	3,65	3,54	3,50	3,48
	SCOP (6)	W/W	4,56	4,46	4,46	4,53
	Water flow rate (4)	L/s	0,23	0,28	0,37	0,47
	User side heat exchanger drops (4)	kPa	1,4	2,1	3,3	9,7
	Energy efficiency water 35°C / 55°C	Classe	A+++/A++	A+++/A++	A+++/A++	A+++/A++
	Compressor	Type		Twin Rotary DC Inverter		
Number of compressors			1	1	1	1
Refrigerant oil (type)			ESTER OIL VG74			
Oil charge (amount)		L	0,45	0,67	0,67	1
Refrigerant circuit			1	1	1	1
Refrigerant	Type		R32	R32	R32	R32
	Refrigerant charge (7)	kg	1,5	1,5	1,5	2,5
	Amount of refrigerant in CO2 tonnes (7)	ton	1,0	1,0	1,0	1,7
	Design pressure (high/low) heat pump mode	bar	42,8/1,3	42,8/1,3	42,8/1,3	42,8/1,3
Design pressure (high/low) chiller mode	bar	42,8/3,5	42,8/3,5	42,8/3,5	42,8/3,5	
Fans	Type		DC Brushless Motor			
	Number		1	1	1	1
Internal heat exchanger	Internal heat exchanger type		Plates			
	N° internal heat exchangers		1	1	1	1
	Water content	L	0,9	0,9	0,9	1,2
Water circuit	Useful head (1)	kPa	80,6	78,8	76,0	68,9
	Water content of hydronic circuit	L	1,4	1,4	1,4	1,8
	Maximum water side pressure	bar	6	6	6	6
	Plumbing fittings	inch	1"M	1"M	1"M	1"M
	Minimum water volume (8)	L	35	40	40	50
	Maximum circulator output	kW	0,08	0,08	0,08	0,08
	Maximum circulator absorbed current	A	0,38	0,38	0,38	0,38
Energy Efficiency Index (EEI) circulator		≤ 0,21	≤ 0,21	≤ 0,21	≤ 0,21	
Noise level	Sound power level Lw (9)	dB(A)	58	64	64	64
Electrical Data	Power supply		230V/1/50Hz			
	Maximum input power	kW	2,1	3,5	3,9	4,6
	Maximum input current	A	10,6	15,1	17,0	20,2
	Maximum input power with antifreeze kit	kW	2,2	3,6	4,0	4,8
	Maximum input current with antifreeze kit	A	11,2	15,6	17,6	20,7

TECHNICAL SPECIFICATIONS		Unit	i-32V5			
			10T	12	12T	14
Cooling	Cooling capacity (1) min/nom/max	kW	4,66 / 7,53 / 8,28*	4,55 / 8,51 / 9,36*	4,55 / 8,51 / 9,36*	6,87 / 11,5 / 12,1*
	Input power (1)	kW	2,39	2,79	2,79	3,53
	E.E.R. (1)	W/W	3,15	3,05	3,05	3,25
	Cooling capacity (2) min/nom/max	kW	6,22 / 9,50 / 10,4*	6,41 / 11,6 / 12,8*	6,41 / 11,6 / 12,8*	9,17 / 14,0 / 14,7*
	Input power (2)	kW	2,15	2,79	2,79	2,59
	E.E.R. (2)	W/W	4,41	4,16	4,16	5,40
	SEER (5)	W/W	4,15	4,25	4,25	4,62
	Water flow rate (1)	L/s	0,36	0,41	0,41	0,55
	User side heat exchanger pressure drops (1)	kPa	6,9	8,8	8,8	12,9
	Heating	Heating capacity (3) min/nom/max	kW	5,33 / 10,1 / 11,6*	5,33 / 11,8 / 13,6*	5,33 / 11,8 / 13,6*
Input power (3)		kW	2,28	2,73	2,73	2,91
C.O.P. (3)		W/W	4,43	4,32	4,32	4,85
Heating capacity (4) min/nom/max		kW	5,18 / 9,76 / 11,2*	5,13 / 11,5 / 13,2*	5,13 / 11,5 / 13,2*	7,23 / 13,6 / 14,6*
Input power (4)		kW	2,80	3,33	3,33	3,55
C.O.P. (4)		W/W	3,48	3,44	3,44	3,82
SCOP (6)		W/W	4,53	4,47	4,47	4,48
Water flow rate (4)		L/s	0,47	0,55	0,55	0,65
User side heat exchanger pressure drops (4)		kPa	9,7	13,1	13,1	13,0
Energy efficiency water 35°C / 55°C		Classe	A+++/A++	A+++/A++	A+++/A++	A+++/A++
Compressor	Type		Twin Rotary DC Inverter			
	Number of compressors		1	1	1	1
	Refrigerant oil (type)		ESTER OIL VG74			
	Oil charge (amount)	L	1	1	1	1,4
	Refrigerant circuits		1	1	1	1
Refrigerant	Type		R32	R32	R32	R32
	Refrigerant charge (7)	kg	2,5	2,5	2,5	3,2
	Amount of refrigerant in equivalent CO2 tonnes (7)	ton	1,7	1,7	1,7	2,2
	Design pressure (high/low) heat pump mode	bar	42,8/1,3	42,8/1,3	42,8/1,3	42,8/1,3
	Design pressure (high/low) chiller mode	bar	42,8/3,5	42,8/3,5	42,8/3,5	42,8/3,5
Fans	Type		DC Brushless Motor			
	Number		1	1	1	2
Internal heat exchanger	Internal heat exchanger type		Plates			
	N° internal heat exchangers		1	1	1	1
	Water content	L	1,2	1,2	1,2	1,7
Water circuit	Useful head (1)	kPa	68,9	63,4	63,4	75,0
	Water content of hydronic circuit	L	1,8	1,8	1,8	3,0
	Maximum water side pressure	bar	6	6	6	6
	Plumbings fittings	inch	1"M	1"M	1"M	1"M
	Minimum water volume (8)	L	50	60	60	60
	Maximum circulator output	kW	0,08	0,08	0,08	0,14
	Maximum circulator absorbed current	A	0,38	0,38	0,38	1,10
Energy Efficiency Index (EEI) circulator		≤ 0,21	≤ 0,21	≤ 0,21	≤ 0,23	
Noise level	Sound power level Lw (9)	dB(A)	64	65	65	68
Electrical data	Power supply		400V/3P+N+T/50Hz	230V/1/50Hz	400V/3P+N+T/50Hz	230V/1/50Hz
	Maximum input power	kW	4,6	5,1	5,1	6,6
	Maximum input current	A	6,6	22,1	7,3	28,6
	Maximum input power with antifreeze kit	kW	4,8	5,2	5,2	6,7
	Maximum input current with antifreeze kit	A	7,0	22,7	7,5	29,2

TECHNICAL SPECIFICATIONS		Unit	i-32V5			
			14T	16	16T	18T
Cooling	Cooling capacity (1) min/nom/max	kW	6,87 / 11,5 / 12,1*	5,99 / 13,8 / 14,5*	5,99 / 13,8 / 14,5*	6,86 / 15,0 / 15,8*
	Input power (1)	kW	3,53	4,38	4,38	4,88
	E.E.R. (1)	W/W	3,25	3,15	3,15	3,08
	Cooling capacity (2) min/nom/max	kW	9,17 / 14,0 / 14,7*	9,20 / 15,8 / 16,6*	9,20 / 15,8 / 16,6*	9,09 / 17,1 / 18,0*
	Input power (2)	kW	2,59	3,15	3,15	3,59
	E.E.R. (2)	W/W	5,40	5,02	5,02	4,76
	SEER (5)	W/W	4,62	4,80	4,80	4,91
	Water flow rate (1)	L/s	0,55	0,66	0,66	0,71
	User side heat exchanger pressure drops (1)	kPa	12,9	17,5	17,5	20,6
	Heating	Heating capacity (3) min/nom/max	kW	7,54 / 14,1 / 15,2*	7,36 / 16,3 / 17,6*	7,36 / 16,3 / 17,6*
Input power(3)		kW	2,91	3,49	3,49	4,07
C.O.P. (3)		W/W	4,85	4,67	4,67	4,40
Heating capacity (4) min/nom/max		kW	7,23 / 13,6 / 14,6*	7,06 / 15,8 / 17,0*	7,06 / 15,8 / 17,0*	7,02 / 17,3 / 18,7*
Input power (4)		kW	3,55	4,24	4,24	4,92
C.O.P. (4)		W/W	3,82	3,72	3,72	3,52
SCOP (6)		W/W	4,48	4,50	4,50	4,46
Water flow rate (4)		L/s	0,65	0,76	0,76	0,83
User side heat exchanger (4)		kPa	13,0	17,6	17,6	21,0
Energy efficiency water 35°C / 55°C		Classe	A+++/A++	A+++/A++	A+++/A++	A+++/A++
Compressor	Type		Twin Rotary DC Inverter			
	Number of compressors		1	1	1	1
	Refrigerant oil (type)		ESTER OIL VG74			
	Oil charge (amount)	L	1,4	1,4	1,4	1,4
	Refrigerant circuits		1	1	1	1
Refrigerant	Type		R32	R32	R32	R32
	Refrigerant charge (7)	kg	3,2	3,5	3,5	3,5
	Amount of refrigerant in equivalent CO2 tonnes (7)	ton	2,2	2,4	2,4	2,4
	Design pressure (high/low) heat pump mode	bar	42,8/1,3	42,8/1,3	42,8/1,3	42,8/1,3
	Design pressure (high/low) chiller mode	bar	42,8/3,5	42,8/3,5	42,8/3,5	42,8/3,5
Fans	Type		DC Brushless Motor			
	Number		2	2	2	2
Internal heat exchanger	Internal heat exchanger type		Plates			
	N° internal heat exchangers		1	1	1	1
	Water content	L	1,7	1,7	1,7	1,7
Water circuit	Useful head (1)	kPa	75,0	62,3	62,3	55,6
	Water content of hydronic circuit	L	3,0	3,0	3,0	3,0
	Maximum water side pressure	bar	6	6	6	6
	Plumbing fittings	inch	1"M	1"M	1"M	1"M
	Minimum water volume (8)	L	60	70	70	70
	Maximum circulator output	kW	0,14	0,14	0,14	0,14
	Maximum circulator absorbed current	A	1,10	1,10	1,10	1,10
Energy Efficiency Index (EEI) circulator		≤ 0,23	≤ 0,23	≤ 0,23	≤ 0,23	
Noise level	Power sound level Lw (9)	dB(A)	68	68	68	68
Electrical data	Power supply		400V/3P+N+T/50Hz	230V/1/50Hz	400V/3P+N+T/50Hz	400V/3P+N+T/50Hz
	Maximum input power	kW	6,6	7,0	7,0	8,3
	Maximum input current	A	9,5	30,4	10,1	12,0
	Maximum input power with antifreeze kit	kW	6,7	7,1	7,1	8,5
	Maximum input current with antifreeze kit	A	9,7	31,0	10,3	12,2

**Performance referring to the following conditions, according to standard 14511:2018:**

- (1) Cooling: outdoor air temperature 35°C; in/out water temperature 12/7°C.  
(2) Cooling: outdoor air temperature 35°C; in/out water temperature 23/18°C.  
(3) Heating: outdoor air temperature 7°C db 6°C db; in/out water temp 30/35°C.  
(4) Heating: outdoor air temperature 7°C db 6°C db; in/out water temp 40/45°C.

- (5) Cooling: in/out water temperature 7/12°C.
- (6) Heating: average climatic conditions; T<sub>biv</sub>=-7°C; in/out water temp 30/35°C.
- (7) Indicative data subject to changes. For the correct value, always refer to the technical label on the unit.
- (8) Sound power level: heating mode condition (3); value calculated based on measurements made in accordance with standard UNI EN ISO 9614-2, compliant with the requirements of the Eurovent certification.
- (9) Sound pressure level: value calculated from the sound power level using ISO 3744:2010.
- (\*) activating the maximum Hz function

**N.B. performance data are indicative and are subject to change. Furthermore the performance declared in points (1), (2), (3) and (4) is intended to refer to instantaneous power according to EN 14511. The value declared in point (5) and (6) is determined according to UNI EN 14825.**

**4.2 SILENCED VERSION DATA TABLE UNIT**

TECHNICAL SPECIFICATIONS		Unit	i-32V5				
			08 SL	12 SL	12T SL	16 SL	16T SL
Cooling	Cooling capacity (1) min/nom/max	kW	3,80 / 6,08 / 6,69*	4,55 / 8,51 / 9,36*	4,55 / 8,51 / 9,36*	5,99 / 13,8 / 14,5*	5,99 / 13,8 / 14,5*
	Input power (1)	kW	1,99	2,79	2,79	4,38	4,38
	E.E.R. (1)	W/W	3,05	3,05	3,05	3,15	3,15
	Cooling capacity (2) min/nom/max	kW	4,91 / 7,72 / 8,49*	6,41 / 11,6 / 12,8*	6,41 / 11,6 / 12,8*	9,20 / 15,8 / 16,6*	9,20 / 15,8 / 16,6*
	Input power (2)	kW	1,76	2,79	2,79	3,15	3,15
	E.E.R. (2)	W/W	4,38	4,16	4,16	5,02	5,02
	SEER (5)	W/W	4,25	4,25	4,25	4,80	4,80
	Water flow rate (1)	L/s	0,28	0,41	0,41	0,66	0,66
	User side heat exchanger pressure drops (1)	kPa	2,8	8,8	8,8	17,5	17,5
Heating	Heating capacity (3) min/nom/max	kW	3,95 / 4,58 / 8,98*	5,33 / 7,35 / 13,6*	5,33 / 7,35 / 13,6*	7,36 / 8,65 / 17,6*	7,36 / 8,65 / 17,6*
	Input power (3)	kW	0,98	1,52	1,52	1,68	1,68
	C.O.P. (3)	W/W	4,67	4,84	4,84	5,15	5,15
	Heating capacity (4) min/nom/max	kW	3,80 / 4,45 / 8,72*	5,13 / 7,14 / 13,2*	5,13 / 7,14 / 13,2*	7,06 / 8,37 / 17,0*	7,06 / 8,37 / 17,0*
	Input power (4)	kW	1,19	1,85	1,85	2,04	2,04
	C.O.P. (4)	W/W	3,72	3,85	3,85	4,10	4,10
	SCOP (6)	W/W	4,58	4,58	4,58	4,72	4,72
	Water flow rate (4)	L/s	0,21	0,34	0,34	0,40	0,40
	User side heat exchanger pressure drops (4)	kPa	1,5	6,1	6,1	8,1	8,1
	Energy efficiency Water 35°C / 55°C		A+++/A++	A+++/A++	A+++/A++	A+++/A++	A+++/A++
Compressor	Type		Twin Rotary DC Inverter				
	Number of compressors		1	1	1	1	1
	Refrigerant oil (type)		ESTER OIL VG74				
	Oil charge (amount)	L	0,67	1	1	1,4	1,4
	Refrigerant circuits		1	1	1	1	1
Refrigerant	Type		R32	R32	R32	R32	R32
	Refrigerant charge (7)	kg	1,5	2,5	2,5	3,5	3,5
	Amount of refrigerant in equivalent CO2 tonnes (7)	ton	1,0	1,7	1,7	2,4	2,4
	Design pressure (high/low) heat pump mode	bar	42,8/1,3	42,8/1,3	42,8/1,3	42,8/1,3	42,8/1,3
	Design pressure (high/low) chiller mode	bar	42,8/3,5	42,8/3,5	42,8/3,5	42,8/3,5	42,8/3,5
Fans	Type		DC Brushless Motor				
	Number		1	1	1	2	2
Internal heat exchanger	Internal heat exchanger type		Plates				
	N° internal heat exchanger		1	1	1	1	1
	Water content	L	0,9	1,2	1,2	1,7	1,7
Water circuit	Useful head (1)	kPa	76,0	63,4	63,4	62,3	62,3
	Water content of hydronic circuit	L	1,4	1,8	1,8	3,0	3,0
	Maximum water side pressure	bar	6	6	6	6	6
	Plumbing fittings	inch	1"M	1"M	1"M	1"M	1"M
	Minimum water volume (8)	L	40	60	60	70	70
	Maximum circulator output	kW	0,08	0,08	0,08	0,14	0,14
	Maximum circulator absorbed current	A	0,38	0,38	0,38	1,10	1,10
Energy Efficiency Index (EEI) circulator		≤ 0,21	≤ 0,21	≤ 0,21	≤ 0,23	≤ 0,23	
Noise level	Sound power level Lw (9)	dB(A)	53	53	53	53	53
Electrical data	Power supply		230V/1/50Hz		400V/3P+N+T/50Hz	230V/1/50Hz	400V/3P+N+T/50Hz
	Maximum input power	kW	3,9	5,1	5,1	7,0	7,0
	Maximum input current	A	17,0	22,1	7,3	30,4	10,1
	Maximum input power with antifreeze kit	kW	4,0	5,2	5,2	7,1	7,1
	Maximum input power with antifreeze kit	A	17,6	22,7	7,5	31,0	10,3

**Performance referring to the following conditions, according to standard 14511:2018:**

- (1) Cooling: outdoor air temperature 35°C; in/out water temperature 12/7°C.
- (2) Cooling: outdoor air temperature 35°C; in/out water temperature 23/18°C.

- (3) Heating: outdoor air temperature 7°C db 6°C db; in/out water temp 30/35°C.
- (4) Heating: outdoor air temperature 7°C db 6°C db; in/out water temp 40/45°C.
- (5) Cooling: in/out water temperature 7/12°C.
- (6) Heating: average climatic conditions; T<sub>biv</sub>=-7°C; in/out water temp 30/35°C.
- (7) Indicative data subject to changes. For the correct value, always refer to the technical label on the unit.
- (8) Sound power level: heating mode condition (3); value calculated based on measurements made in accordance with standard UNI EN ISO 9614-2, compliant with the requirements of the Eurovent certification.
- (9) Sound Pressure: Value calculated from sound power level using ISO 3744:2010.
- (\*) activating the maximum Hz function

### 4.3 ELECTRICAL AND AUXILIARY DATA

<b>Power supply</b>	V/~ /Hz	230/1PH+PE/50*- 400/3PH+PE/50**	<b>Remote controller circuit</b>	V/~ /Hz	12/1/50
<b>On board controller circuit</b>	V/~ /Hz	12/1/50	<b>Fans power supply</b>	V/~ /Hz	230/1/50

For sizes 04,06,08,SL08,10,12,SL12,14 and 16, SL16\* - For sizes 10T,12T,SL12T,14T,16T,SL16T and 18T\*\*

**NOTE: The electrical data are subject to change due to updates. It is therefore always necessary to refer to the technical specifications label applied on the right side panel of the unit.**

## 5. CORRECTION FACTORS

### 5.1 CORRECTION FACTORS FOR USE OF GLYCOL WATER MIXTURE

The correction factors of the water flow rate and pressure drops must be applied to the values obtained without use of glycol. The water flow rate correction factor is calculated to retain the same temperature difference which would be achieved without using glycol. The pressure drop correction factor is applied to the correct water flow rate value of the water flow rate correction factor.

Glycol percentage	Freezing point [°C]	Performance correction factor	Absorbed power correction factor	Water flow rate correction factor	Pressure drops correction factor
10%	-3,2	0,985	1	1,02	1,08
20%	-7,8	0,98	0,99	1,05	1,12
30%	-14,1	0,97	0,98	1,10	1,22
40%	-22,3	0,965	0,97	1,14	1,25
50%	-33,8	0,955	0,965	1,2	1,33

### 5.2 SCALING CORRECTION FACTORS

The following are the correction factors due to fouling of the internal gas/water heat exchanger.

m <sup>2</sup> °C/kW	Output power correction factor	Input power correction factor
0,44 x 10 <sup>-1</sup>	1,00	1,00
0,88 x 10 <sup>-1</sup>	0,99	1,00
1,76 x 10 <sup>-1</sup>	0,98	1,00

### 5.3 INSTRUMENTATION CALIBRATIONS AND PROTECTIONS

Description	Value
High pressure switch	42,8 bar
High pressure alarm	41,5 bar
Low pressure alarm	Depends on the unit
Maximum number of restarts/hour after high/low pressure alarm (manual reset)	3
Frost protection	Allarm triggered: 4 °C Allarm return: +7°C
Hydronic circuit safety valve	6 bar

### 5.4 CORRECTION FACTORS ACCORDING TO ALTITUDE

The performance correction factors according to altitude are calculated for cooling at conditions (1) and for heating at conditions (3) of the previous technical data tables and are provided for altitudes of 500, 1000, 1500 and 2000 m.

i-32V5				
Altitude [m]	500	1000	1500	2000
Thermal output correction factor	0,9964	0,9941	0,9888	0,9869
Power input correction factor in heating	0,9931	0,9841	0,9853	0,9755
Cooling output correction factor	0,9888	0,9762	0,9618	0,9466
Power input correction factor in cooling	1,0106	1,0235	1,0386	1,0560

## 6. HYDRONIC UNIT DATA

### 6.1 USEFUL HEADS

The following are the characteristic curves of the head-flow rate net of the pressure drops of the hydronic kit. It highlights the ideal working point on each curve at the conditions specified at the apex (4) shown in the technical data table.

The system must be designed to guarantee the nominal flow rate relative to the working points shown below.

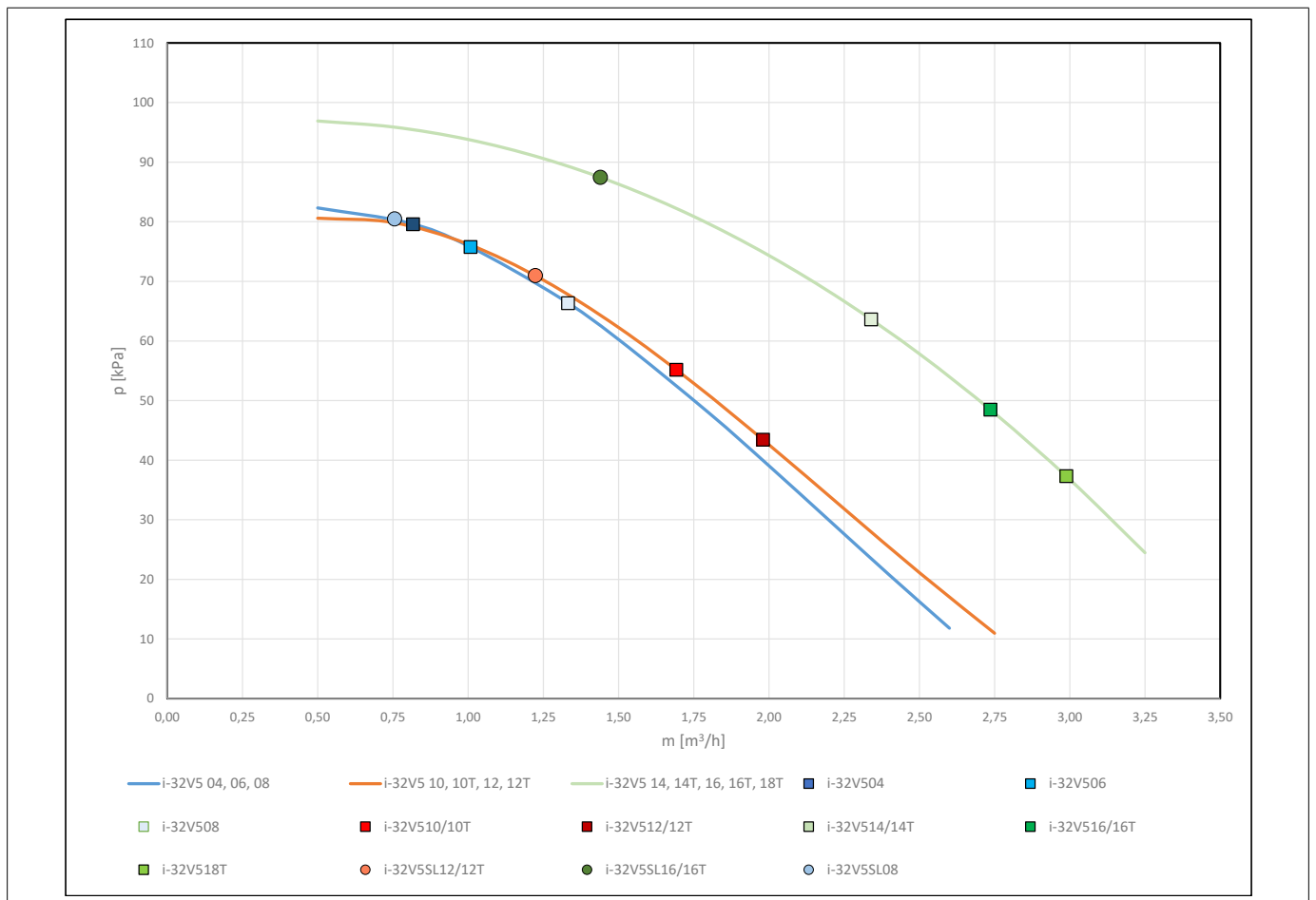

### 6.2 CHARACTERISTIC CURVES OF CIRCULATORS

Below is the range of useful heads which guarantee the unit during modulating of the circulator.

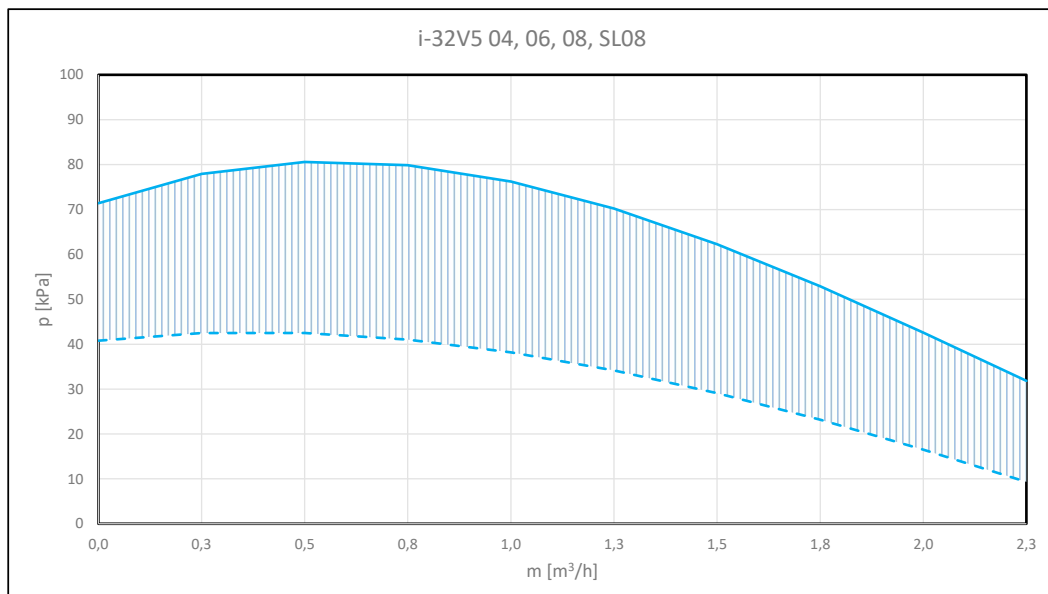

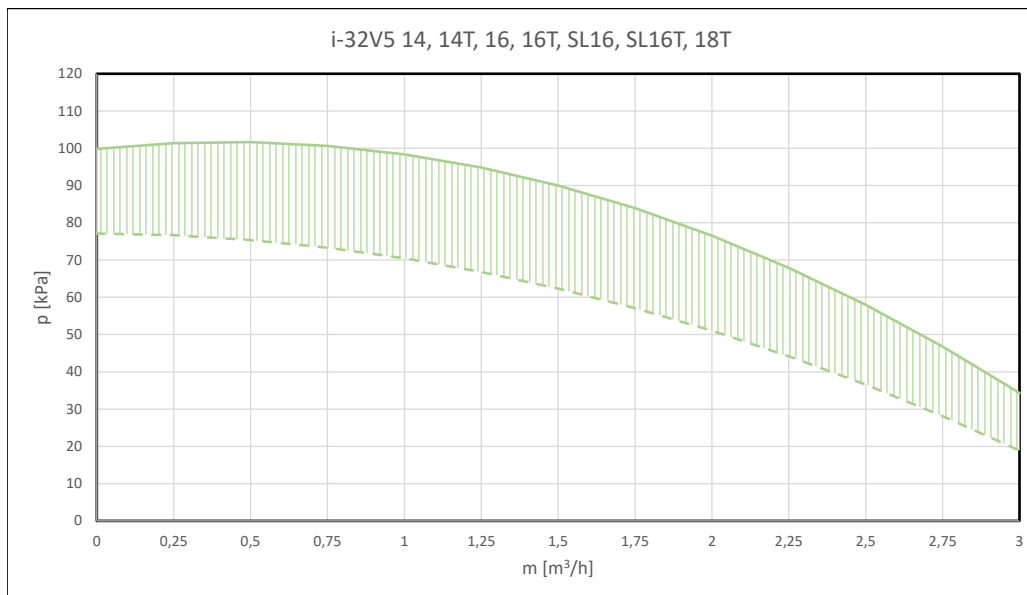
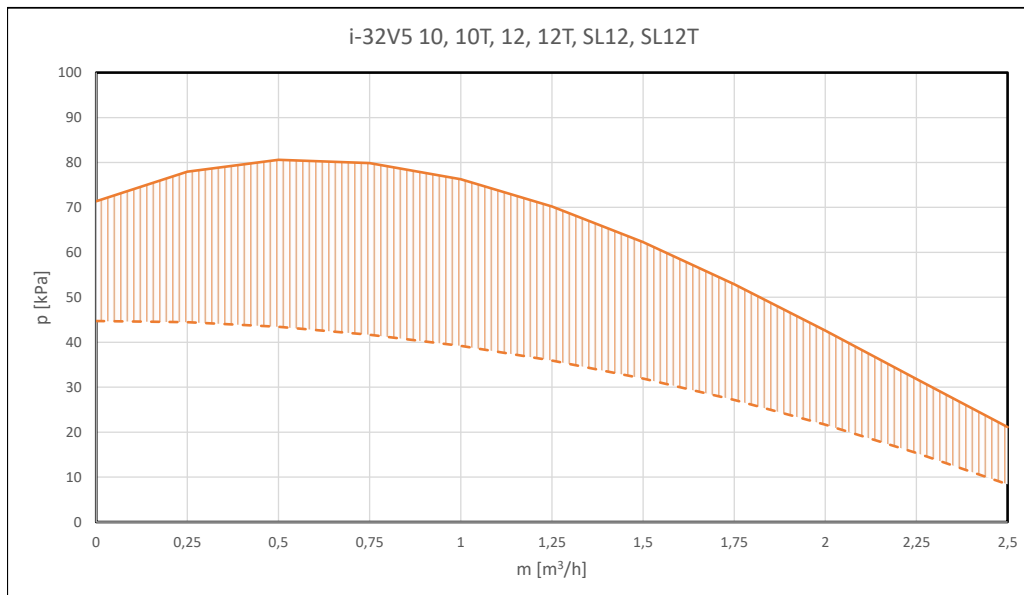

## 7. NOISE LEVEL

The sound levels are referred to units at full load and in normal test conditions in heating mode according with EU 813/2013 regulation (ambient air temperature 7°C d.b., water temperature 47°/55°C). The tolerance on the value of the total sound power level is 2 dB (A). The value is calculated according with EN 12102-1:2017 regulation used in conjunction with UNI EN ISO 9614-2 which describes the test methods with the intensimetric method.

The sound pressure values are calculated from the sound power level using ISO 3744: 2010, considering units operating in the open field.

Model i-32V5	Octave band sound power level [dB(A)]						Sound power level Lw(A) [dB(A)]	Sound pressure level at 1m [dB(A)]	Sound pressure level at 10m [dB(A)]
	125 Hz	250 Hz	500 Hz	1000 Hz	2000 Hz	4000 Hz			
<b>4</b>	39,1	49,8	52	54,7	49,9	43,1	58	43,8	26,8
<b>6</b>	46,8	57,5	55,7	59,7	57,6	51,6	64	49,8	32,8
<b>8</b>	47	57,7	55,9	59,9	57,8	51,8	64	49,8	32,8
<b>SL08</b>	35	35	41	47,5	49	46,1	53	38,8	21,8
<b>10/10T</b>	48,5	53,5	58,1	60,2	56,7	54,6	64	49,4	32,7
<b>12/12T</b>	48,8	53,8	58,4	60,5	57	54,9	65	50,4	33,7
<b>SL12/ SL12T</b>	37,1	36	44,1	48,6	47,8	43,8	53	38,4	21,7
<b>14/14T</b>	52,4	63,1	61,8	63	57,6	55,2	68	52,7	36,6
<b>16/16T</b>	52,6	63,3	62	63,2	57,8	55,4	68	52,7	36,6
<b>SL16/ SL16T</b>	39,1	36,1	44,7	48,5	44,9	42,6	53	37,7	21,6
<b>18T</b>	52,7	63,4	62,1	63,3	57,9	55,5	68	52,7	36,6

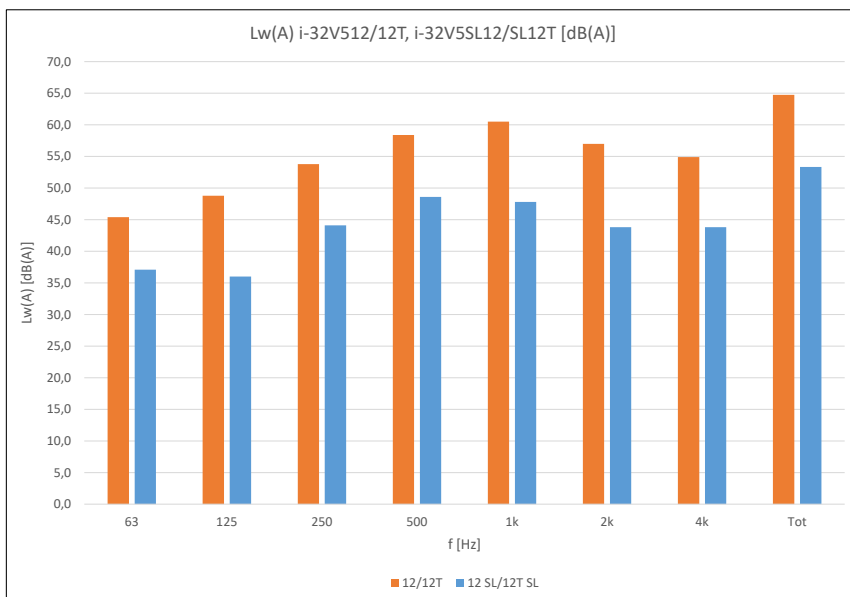
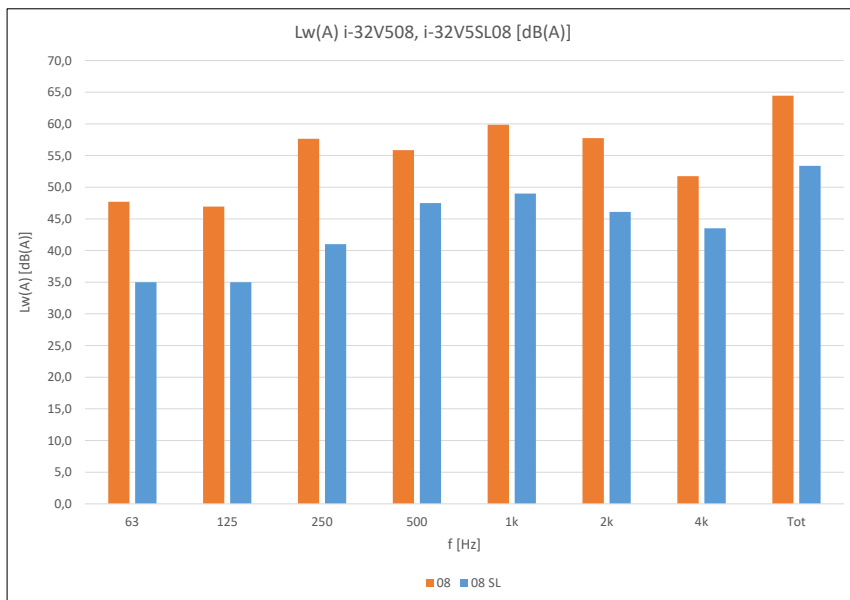
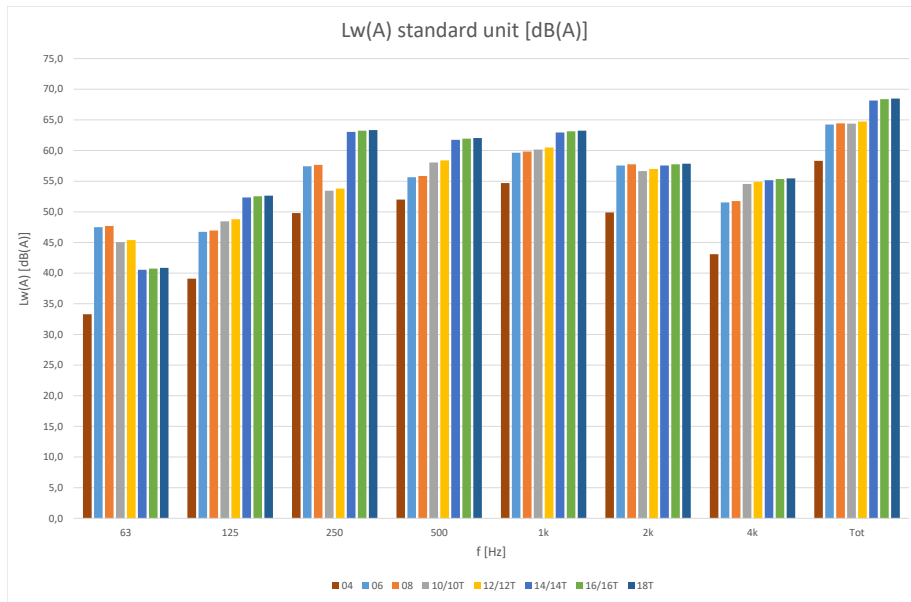

## 8. OPERATING LIMITS

### 8.1 EVAPORATOR WATER FLOW

The nominal water flow rate refers to a 5°C temperature difference between the evaporator inlet and outlet. The maximum permitted flow rate features a 3°C temperature difference while the minimum one has an 8°C temperature difference at the nominal conditions as shown in the technical sheet.

**Insufficient water flow rates can cause excessively low evaporation temperatures causing the safety devices to trigger and stopping the unit and, in some extreme cases, forming ice in the evaporator and resulting in serious failures to the cooling circuit.**

For greater details, we have attached a table below with the minimum flow rates for the plate heat exchanger to guarantee proper operation according to the model (please note: the water flow switch is applied to protect against failed triggering of the antifreeze probe due to the lack of flow but does not guarantee the minimum water flow rate required for correct operation of the unit).

Model i-32V5	04	06	08,SL08	10	10T	12, SL12	12T, SL12T	14	14T	16, SL16	16T, SL16T	18T
Minimum water flow to be assured in chiller mode (condition (1) technical sheet) [l/s]	0,13	0,15	0,17	0,23		0,25		0,34		0,34		0,41
Maximum water flow to be assured in chiller mode (condition (1) technical sheet) [l/s]	0,34	0,40	0,46	0,60		0,68		0,92		0,92		1,10
Flow switch trip flow rate – decreasing flow* [l/s]	0,117	0,117	0,117	0,153		0,153		0,153		0,262		0,262
Flow switch trip flow rate – increasing flow* [l/s]	0,132	0,132	0,132	0,175		0,175		0,175		0,293		0,293

\* When the flow rate drops below the indicated limit (flow switch trip flow rate – decreasing flow) the flow switch issues an alarm, which may be reset only upon reaching the flow switch trip flow rate – increasing flow.

As an approximation, and without any other measurement systems, the correct flow rate to guarantee the best performance of the unit can be verified with the circulator at maximum speed, by looking at the pressure gauges to check the pressure difference between the water return and delivery on the external plumbing fittings of the unit and making sure that this reading is equal to or lower than the useful head indicated on the curves shown in Paragraph 6.2 for the respective models.

### 8.2 COLD WATER PRODUCTION (SUMMER MODE)

A minimum temperature of 5°C is allowed at the evaporator outlet: for lower temperatures, contact the Technical Department. In this case contact our technical department to study the feasibility and assess the changes to be made according to demands. A maximum temperature of 25°C can be maintained at the evaporator outlet in steady-state operation. Higher temperatures (up to a maximum of 40°C) can however be tolerated in transients and in reaching steady-state phases.

### 8.3 HOT WATER PRODUCTION (WINTER MODE)

When the system has reached steady state, the water inlet temperature must not drop below 25°C: lower values, not due to transient phases or reaching steady-state, can cause system failures and could possibly break the compressor. The maximum outlet water temperature must not exceed 60°C. At this temperature, power absorption and COP are optimised if the outdoor temperature is higher than 5°C, even though the unit is capable of working at the limit temperatures shown in the envelope.

There could be failures to the regular operation of the unit or, in more critical cases, the safety devices could be triggered due to temperatures higher than those indicated, especially if coupled with reduced water flow rates.

### 8.4 AMBIENT AIR TEMPERATURE AND SUMMARY TABLE

The units are designed and built to operate in summer mode, with condensation control, at outdoor air temperatures between -10°C and 46°C. In heat pump mode, the allowed temperature range of the outdoor air goes from -20°C to +40°C depending on the outlet water temperature as shown in the table below.

Water chiller mode		
Room temperature	Minimum -10°C	Maximum +46°C
Outlet water temperature	Minimum +5°C	Maximum +25°C
Heat pump mode		
Room temperature	Minimum -20°C	Maximum +30°C
Outlet water temperature	Minimum +25°C	Maximum +60°C
Heat pump mode for domestic hot water		
Room temperature with water at maximum 39°C	Minimum -20°C	Maximum +40°C
Room temperature with water at maximum 55°C	Minimum -10°C	Maximum +35°C
Outlet water temperature	Minimum +25°C	Maximum +60°C

### 8.5 ENVELOPE IN HEATING AND COOLING

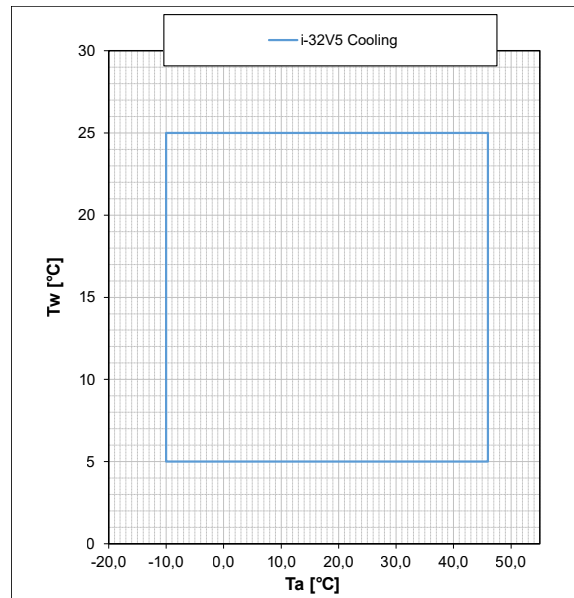
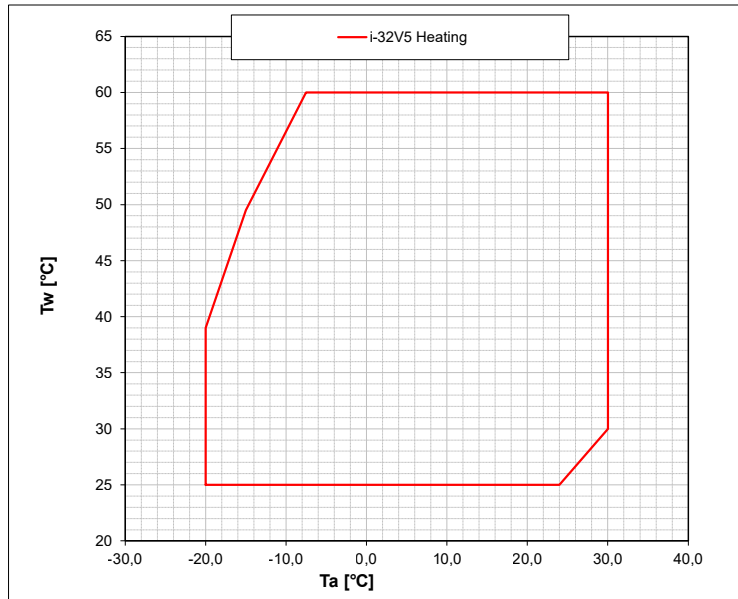

### 8.6 ENVELOPE IN DHW

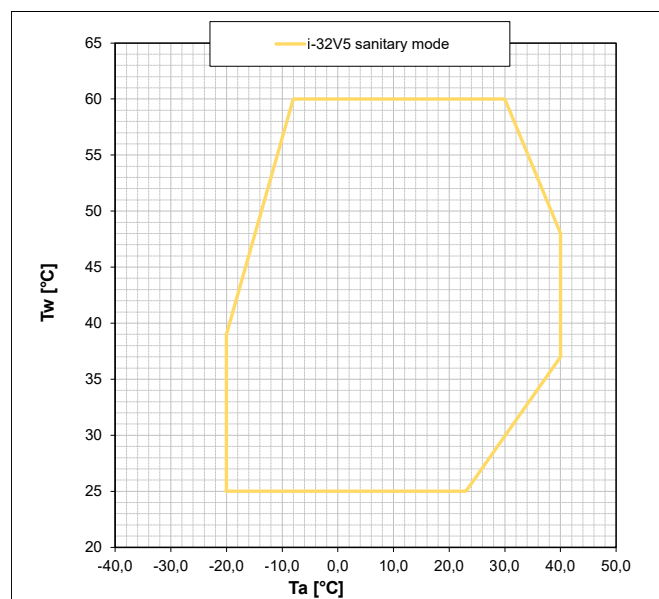

## 9. PERFORMANCE TABLES

The tables show the capacity, power input and efficiency values for different outside air temperatures. The data shown are calculated according to EN 14511:2018. They are indicative and may be subject to change.

### 9.1 HEATING STANDARD UNIT VERSION

Model i-32V5		HEATING																							
		T air outdoor [°C]	T <sub>out</sub> [°C]																						
			25			30			35			40			45			50			55			60	
Heating capacity [kW]	Power input [kW]	COP [W/W]	Heating capacity [kW]	Power input [kW]	COP [W/W]	Heating capacity [kW]	Power input [kW]	COP [W/W]	Heating capacity [kW]	Power input [kW]	COP [W/W]	Heating capacity [kW]	Power input [kW]	COP [W/W]	Heating capacity [kW]	Power input [kW]	COP [W/W]	Heating capacity [kW]	Power input [kW]	COP [W/W]	Heating capacity [kW]	Power input [kW]	COP [W/W]		
04	-15	3,98	1,29	3,09	3,97	1,41	2,82	3,95	1,53	2,58	3,99	1,66	2,40	4,07	1,86	2,19	-	-	-	-	-	-	-	-	-
	-10	3,93	1,14	3,45	3,89	1,24	3,14	3,87	1,36	2,85	3,86	1,47	2,63	3,94	1,67	2,36	3,96	1,81	2,19	3,92	1,93	2,03	-	-	-
	-7	4,03	1,09	3,70	3,99	1,20	3,32	3,96	1,30	3,05	3,96	1,43	2,77	4,02	1,61	2,50	4,00	1,74	2,30	4,00	1,89	2,12	4,00	2,05	1,95
	-2	4,16	0,98	4,24	4,13	1,09	3,79	4,11	1,22	3,37	4,08	1,33	3,07	4,11	1,51	2,72	4,10	1,63	2,52	4,05	1,77	2,29	4,04	1,91	2,12
	2	4,47	0,87	5,14	4,36	0,96	4,54	4,37	1,08	4,05	4,42	1,23	3,59	4,55	1,43	3,18	4,35	1,58	2,75	4,29	1,73	2,48	4,24	1,88	2,26
	7	4,61	0,73	6,32	4,61	0,85	5,42	4,76	1,00	4,76	4,52	1,08	4,19	4,75	1,30	3,65	4,59	1,40	3,28	4,53	1,54	2,94	4,44	1,67	2,66
	12	4,97	0,63	7,89	4,93	0,75	6,57	4,89	0,86	5,69	4,83	0,99	4,88	4,89	1,16	4,22	4,82	1,29	3,74	4,74	1,43	3,31	4,68	1,58	2,96
	15	5,04	0,60	8,40	4,90	0,70	7,00	4,78	0,80	5,98	4,81	0,93	5,17	4,85	1,10	4,41	4,77	1,23	3,88	4,71	1,38	3,41	4,64	1,52	3,05
	20	4,94	0,57	8,67	4,73	0,65	7,28	4,70	0,70	6,71	4,59	0,80	5,74	4,66	0,94	4,96	4,59	1,07	4,29	4,54	1,20	3,78	4,52	1,34	3,37
	25	-	-	-	5,06	0,60	8,43	4,87	0,68	7,16	4,82	0,73	6,60	4,86	0,86	5,65	4,80	0,99	4,85	4,72	1,12	4,22	4,65	1,25	3,74
30	-	-	-	5,48	0,55	9,96	5,23	0,66	7,92	5,19	0,68	7,76	5,21	0,83	6,39	5,18	0,97	5,45	5,11	1,12	4,67	5,03	1,27	4,07	
06	-15	5,88	1,95	3,02	5,82	2,13	2,74	5,85	2,33	2,51	5,84	2,56	2,28	5,91	2,72	2,17	-	-	-	-	-	-	-	-	-
	-10	5,95	1,77	3,35	5,87	1,94	3,02	5,82	2,11	2,76	5,82	2,35	2,48	5,83	2,50	2,33	5,83	2,76	2,11	5,84	2,90	2,01	-	-	-
	-7	5,96	1,67	3,57	5,92	1,84	3,22	6,00	2,10	2,86	5,86	2,19	2,67	5,85	2,39	2,44	5,89	2,62	2,25	5,84	2,87	2,03	5,79	3,12	1,85
	-2	5,95	1,45	4,10	5,89	1,64	3,60	5,92	1,84	3,22	5,77	1,97	2,93	5,86	2,20	2,67	5,78	2,36	2,45	5,76	2,65	2,17	5,75	2,94	1,95
	2	5,92	1,23	4,79	5,93	1,39	4,26	6,07	1,59	3,82	5,85	1,75	3,34	5,77	1,88	3,06	6,00	2,17	2,76	5,99	2,32	2,58	5,97	2,48	2,41
	7	6,21	1,05	5,93	6,13	1,19	5,14	6,08	1,35	4,51	6,04	1,53	3,93	5,88	1,66	3,54	6,07	1,93	3,15	6,03	2,14	2,82	5,99	2,35	2,55
	12	6,68	0,91	7,37	6,65	1,07	6,22	6,57	1,25	5,25	6,55	1,41	4,64	6,53	1,63	4,02	6,38	1,79	3,56	6,31	1,98	3,19	6,24	2,17	2,88
	15	6,57	0,84	7,80	6,54	1,00	6,52	6,59	1,19	5,56	6,47	1,36	4,77	6,47	1,54	4,20	6,32	1,71	3,70	6,26	1,90	3,29	6,19	2,09	2,96
	20	6,49	0,76	8,56	6,33	0,86	7,38	6,31	1,02	6,20	6,14	1,14	5,37	6,13	1,32	4,66	6,02	1,47	4,11	6,00	1,68	3,58	5,98	1,89	3,16
	25	-	-	-	6,48	0,79	8,18	6,33	0,87	7,26	6,24	1,05	5,96	6,18	1,19	5,17	6,06	1,34	4,51	6,08	1,54	3,95	6,11	1,74	3,51
30	-	-	-	6,54	0,73	9,00	6,57	0,78	8,38	6,45	0,91	7,05	6,38	1,10	5,80	6,39	1,28	4,98	6,29	1,41	4,47	6,19	1,53	4,04	
08	-15	6,50	2,18	2,98	6,49	2,39	2,72	6,48	2,60	2,49	6,48	2,79	2,32	6,44	2,94	2,19	-	-	-	-	-	-	-	-	-
	-10	6,63	2,02	3,29	6,60	2,19	3,01	6,59	2,44	2,70	6,52	2,63	2,48	6,48	2,79	2,32	6,52	3,02	2,16	6,53	3,34	1,96	-	-	-
	-7	6,64	1,90	3,50	6,64	2,09	3,17	6,60	2,29	2,88	6,49	2,42	2,68	6,57	2,71	2,42	6,51	2,88	2,26	6,54	3,13	2,09	6,57	3,37	1,95
	-2	6,70	1,69	3,97	6,66	1,86	3,59	6,56	2,07	3,17	6,53	2,29	2,86	6,55	2,46	2,67	6,52	2,69	2,42	6,49	2,99	2,17	6,46	3,28	1,97
	2	6,70	1,42	4,73	6,74	1,62	4,17	6,61	1,77	3,72	6,59	1,96	3,37	6,58	2,13	3,08	6,60	2,35	2,81	6,67	2,63	2,53	6,75	2,92	2,31
	7	7,74	1,32	5,86	7,78	1,54	5,05	7,81	1,78	4,38	7,70	1,97	3,91	7,58	2,17	3,50	7,55	2,40	3,15	7,55	2,65	2,85	7,55	2,90	2,60
	12	8,27	1,17	7,10	8,27	1,37	6,04	8,16	1,56	5,22	8,09	1,78	4,55	7,98	1,97	4,05	7,87	2,20	3,57	7,79	2,45	3,18	7,70	2,69	2,86
	15	8,17	1,08	7,59	8,12	1,28	6,35	8,19	1,50	5,47	8,04	1,71	4,71	8,04	1,94	4,15	7,87	2,12	3,71	7,76	2,38	3,27	7,66	2,63	2,91
	20	7,99	0,94	8,47	7,91	1,12	7,04	7,88	1,34	5,88	7,66	1,53	5,02	7,66	1,71	4,47	7,70	1,97	3,92	7,54	2,15	3,50	7,37	2,34	3,15
	25	-	-	-	8,03	0,97	8,31	7,96	1,16	6,84	7,88	1,37	5,75	7,86	1,58	4,97	7,80	1,81	4,32	7,62	1,99	3,83	7,44	2,18	3,42
30	-	-	-	8,41	0,87	9,62	8,38	1,09	7,70	8,27	1,30	6,39	8,17	1,49	5,48	8,11	1,72	4,71	8,02	1,95	4,11	7,94	2,19	3,63	
10 10T	-15	8,29	2,77	2,99	8,32	3,02	2,76	8,25	3,26	2,53	8,29	3,60	2,30	8,33	3,85	2,17	-	-	-	-	-	-	-	-	-
	-10	8,33	2,52	3,30	8,22	2,72	3,03	8,22	2,99	2,75	8,19	3,28	2,50	8,17	3,53	2,31	8,22	3,86	2,13	8,11	4,05	2,00	-	-	-
	-7	8,41	2,38	3,54	8,42	2,65	3,18	8,30	2,86	2,90	8,35	3,18	2,63	8,23	3,38	2,44	8,25	3,69	2,23	8,26	4,00	2,06	8,28	4,31	1,92
	-2	8,63	2,16	3,99	8,52	2,38	3,58	8,56	2,68	3,19	8,51	2,94	2,89	8,40	3,21	2,61	8,35	3,52	2,37	8,31	3,82	2,18	8,28	4,12	2,01
	2	9,15	1,89	4,85	9,22	2,15	4,29	9,50	2,51	3,78	9,18	2,69	3,41	9,41	3,11	3,03	9,28	3,37	2,75	9,01	3,63	2,48	8,74	3,88	2,25
	7	10,2	1,75	5,84	10,2	2,02	5,04	10,1	2,28	4,43	10,0	2,58	3,89	9,76	2,80	3,48	9,79	3,17	3,09	9,73	3,50	2,78	9,67	3,83	2,53
	12	10,9	1,53	7,12	10,8	1,79	6,04	10,7	2,09	5,14	10,6	2,39	4,45	10,5	2,69	3,90	10,4	2,99	3,47	10,2	3,31	3,09	10,1	3,62	2,78
	15	11,0	1,44	7,58	10,9	1,72	6,32	10,7	2,00	5,36	10,6	2,29	4,64	10,5	2,59	4,07	10,4	2,91	3,58	10,2	3,21	3,20	10,1	3,50	2,88
	20	10,8	1,28	8,41	10,7	1,53	6,95	10,6	1,80	5,87	10,4	2,09	5,01	10,3	2,36	4,37	10,2	2,66	3,83	10,0	2,95	3,41	9,91	3,24	3,06
	25	-	-	-	10,6	1,30	8,16	10,5	1,59	6,61	10,4	1,84	5,65	10,2	2,09	4,89	10,1	2,38	4,23	9,92	2,68	3,70	9,78	2,99	3,27
30	-	-	-	11,1	1,28	8,69	11,0	1,46	7,54	10,9	1,74	6,22	10,7	2,02	5,30	10,6	2,33	4,55	10,4	2,58	4,03	10,2	2,83	3,60	

Model i-32V5		HEATING																							
		T air outdoor [°C]	Tout [°C]																						
			25			30			35			40			45			50			55			60	
Heating capacity [kW]	Power input [kW]	COP [W/W]	Heating capacity [kW]	Power input [kW]	COP [W/W]	Heating capacity [kW]	Power input [kW]	COP [W/W]	Heating capacity [kW]	Power input [kW]	COP [W/W]	Heating capacity [kW]	Power input [kW]	COP [W/W]	Heating capacity [kW]	Power input [kW]	COP [W/W]	Heating capacity [kW]	Power input [kW]	COP [W/W]	Heating capacity [kW]	Power input [kW]	COP [W/W]		
12 12T	-15	8,98	3,06	2,93	9,01	3,36	2,68	8,94	3,63	2,47	8,97	3,92	2,29	9,03	4,25	2,12	-	-	-	-	-	-	-	-	
	-10	8,95	2,76	3,25	8,93	3,07	2,91	8,86	3,29	2,70	8,92	3,65	2,44	8,83	3,88	2,27	8,71	4,12	2,11	8,85	4,52	1,96	-	-	-
	-7	9,01	2,59	3,47	8,93	2,83	3,15	8,90	3,12	2,85	8,85	3,39	2,61	8,91	3,73	2,39	8,75	3,96	2,21	8,85	4,34	2,04	8,95	4,72	1,90
	-2	9,54	2,43	3,92	9,50	2,73	3,48	9,40	2,98	3,16	9,45	3,41	2,77	9,25	3,55	2,61	9,19	3,90	2,36	9,15	4,18	2,19	9,10	4,47	2,04
	2	10,2	2,20	4,66	10,2	2,44	4,17	10,3	2,78	3,71	10,4	3,12	3,33	10,4	3,45	3,02	10,1	3,65	2,75	10,2	4,09	2,49	10,3	4,52	2,28
	7	12,0	2,13	5,63	11,9	2,40	4,95	11,8	2,73	4,32	11,7	3,03	3,87	11,5	3,33	3,44	11,5	3,69	3,11	11,4	4,10	2,78	11,3	4,50	2,50
	12	12,5	1,75	7,12	12,4	2,07	5,99	12,3	2,38	5,15	12,1	2,70	4,48	12,0	3,04	3,94	11,8	3,40	3,48	11,7	3,72	3,14	11,5	4,04	2,85
	15	12,1	1,60	7,56	12,0	1,89	6,36	11,9	2,19	5,43	11,8	2,50	4,72	11,7	2,82	4,13	11,5	3,15	3,66	11,3	3,48	3,26	11,2	3,81	2,93
	20	11,1	1,28	8,63	10,9	1,54	7,11	10,8	1,79	6,04	10,7	2,05	5,23	10,6	2,35	4,50	10,4	2,63	3,97	10,3	2,92	3,53	10,2	3,21	3,17
	25	-	-	-	10,7	1,26	8,53	10,6	1,51	7,01	10,5	1,77	5,89	10,3	2,02	5,10	10,2	2,30	4,41	10,0	2,58	3,88	9,87	2,85	3,46
30	-	-	-	11,2	1,22	9,19	11,1	1,39	7,96	10,9	1,66	6,59	10,8	1,92	5,60	10,7	2,23	4,79	10,5	2,46	4,27	10,3	2,68	3,84	
14 14T	-15	10,9	3,72	2,92	10,8	4,05	2,66	10,8	4,37	2,47	10,8	4,78	2,25	10,8	5,29	2,05	-	-	-	-	-	-	-	-	
	-10	10,7	3,23	3,31	10,7	3,55	3,00	10,6	3,90	2,73	10,7	4,27	2,49	10,5	4,55	2,31	10,5	4,93	2,13	10,3	5,12	2,01	-	-	-
	-7	10,9	3,01	3,62	10,8	3,31	3,26	10,7	3,63	2,95	10,7	4,00	2,68	10,7	4,36	2,44	10,7	4,83	2,21	10,6	5,05	2,09	10,5	5,28	1,99
	-2	11,2	2,65	4,25	11,5	3,08	3,72	11,4	3,41	3,34	11,3	3,73	3,02	11,2	4,08	2,74	11,1	4,43	2,51	11,0	4,72	2,33	10,9	5,01	2,17
	2	12,4	2,41	5,16	12,5	2,81	4,46	13,0	3,24	4,02	12,5	3,46	3,62	12,7	3,92	3,24	12,4	4,21	2,95	12,4	4,57	2,71	12,4	4,93	2,52
	7	14,3	2,24	6,36	14,1	2,56	5,51	14,1	2,91	4,85	13,9	3,23	4,30	13,6	3,55	3,82	13,6	4,00	3,41	13,4	4,35	3,09	13,3	4,70	2,82
	12	15,0	1,83	8,20	14,9	2,18	6,83	14,7	2,48	5,94	14,6	2,83	5,15	14,4	3,19	4,52	14,1	3,53	4,00	14,0	3,92	3,56	13,8	4,30	3,20
	15	15,0	1,69	8,85	14,8	1,99	7,44	14,7	2,33	6,31	14,5	2,66	5,47	14,4	3,00	4,80	14,0	3,32	4,23	14,0	3,70	3,77	13,9	4,09	3,40
	20	14,9	1,42	10,5	14,7	1,70	8,66	14,6	2,01	7,25	14,4	2,32	6,19	14,4	2,64	5,44	14,0	2,92	4,80	14,1	3,32	4,24	14,1	3,72	3,80
	25	-	-	-	15,0	1,40	10,7	15,0	1,71	8,75	14,7	1,99	7,38	14,5	2,28	6,36	14,5	2,63	5,51	14,1	2,90	4,87	13,8	3,17	4,34
30	-	-	-	16,0	1,26	12,7	15,9	1,57	10,1	15,5	1,86	8,33	15,3	2,18	7,02	15,1	2,52	6,02	14,8	2,84	5,23	14,5	3,16	4,60	
16 16T	-15	10,3	3,62	2,84	10,2	4,00	2,56	10,2	4,33	2,36	10,2	4,62	2,20	10,8	5,32	2,03	-	-	-	-	-	-	-	-	
	-10	11,9	3,71	3,20	11,8	4,07	2,91	11,8	4,42	2,67	11,8	4,82	2,44	11,6	5,15	2,25	11,6	5,56	2,09	11,3	5,88	1,92	-	-	-
	-7	12,3	3,56	3,45	12,2	3,90	3,13	12,0	4,20	2,86	12,0	4,61	2,60	11,9	4,86	2,44	11,8	5,33	2,21	11,8	5,75	2,05	11,8	6,18	1,91
	-2	12,7	3,18	3,99	12,9	3,57	3,61	12,8	3,97	3,23	12,7	4,30	2,94	12,6	4,68	2,68	12,5	5,07	2,45	12,4	5,51	2,25	12,3	5,96	2,07
	2	14,0	2,90	4,83	14,2	3,29	4,30	14,1	3,62	3,88	14,0	4,02	3,49	14,4	4,59	3,13	14,1	4,91	2,87	14,2	5,44	2,60	14,2	5,97	2,38
	7	16,6	2,74	6,05	16,4	3,09	5,30	16,3	3,49	4,67	16,1	3,90	4,13	15,8	4,24	3,72	15,8	4,77	3,32	15,6	5,18	3,02	15,4	5,60	2,75
	12	16,4	2,08	7,91	16,3	2,45	6,65	16,1	2,79	5,77	16,0	3,18	5,02	15,8	3,57	4,43	15,5	3,94	3,93	15,3	4,35	3,51	15,1	4,77	3,16
	15	17,0	1,99	8,54	16,8	2,34	7,18	16,7	2,71	6,14	16,5	3,10	5,32	16,3	3,50	4,67	15,9	3,86	4,13	15,9	4,30	3,69	15,8	4,74	3,33
	20	16,9	1,70	9,95	16,8	2,03	8,26	16,6	2,37	7,00	16,4	2,72	6,02	16,3	3,11	5,25	16,0	3,43	4,65	16,0	3,89	4,12	16,1	4,34	3,71
	25	-	-	-	17,1	1,67	10,2	17,0	2,02	8,41	16,8	2,36	7,10	16,5	2,70	6,12	16,5	3,09	5,33	16,1	3,42	4,70	15,7	3,74	4,18
30	-	-	-	18,8	1,55	12,1	18,6	1,93	9,66	18,2	2,28	7,99	18,0	2,68	6,74	17,8	3,08	5,78	17,5	3,47	5,02	17,1	3,87	4,42	
18T	-15	11,7	4,05	2,89	11,8	4,49	2,63	11,8	4,90	2,41	11,8	5,26	2,25	12,1	5,79	2,08	-	-	-	-	-	-	-	-	
	-10	12,2	3,82	3,19	12,2	4,18	2,91	12,3	4,62	2,66	11,8	4,79	2,47	12,0	5,31	2,26	12,1	5,76	2,10	11,4	6,05	1,88	-	-	-
	-7	12,9	3,77	3,43	12,5	4,03	3,11	12,6	4,46	2,83	12,4	4,77	2,60	12,5	5,26	2,37	12,3	5,58	2,20	12,3	6,04	2,04	12,3	6,49	1,90
	-2	13,8	3,58	3,85	13,5	3,86	3,49	13,6	4,32	3,15	13,4	4,68	2,87	13,4	5,09	2,62	13,3	5,57	2,38	13,1	5,96	2,21	13,0	6,35	2,05
	2	14,9	3,21	4,66	14,7	3,53	4,17	15,1	3,97	3,81	15,0	4,45	3,37	14,9	4,89	3,05	14,6	5,31	2,76	14,7	5,60	2,63	14,8	5,89	2,52
	7	18,1	3,23	5,62	18,0	3,65	4,94	17,9	4,07	4,40	17,6	4,52	3,91	17,3	4,92	3,52	17,3	5,45	3,18	17,3	5,99	2,88	17,2	6,53	2,63
	12	18,7	2,62	7,13	18,5	3,03	6,10	18,3	3,45	5,29	18,1	3,89	4,65	17,7	4,27	4,14	17,6	4,76	3,69	17,3	5,24	3,31	17,1	5,73	2,98
	15	18,3	2,39	7,67	18,2	2,78	6,55	18,0	3,21	5,60	17,8	3,62	4,92	17,6	4,06	4,33	17,2	4,46	3,86	17,1	4,96	3,45	17,0	5,46	3,12
	20	17,6	1,98	8,91	17,4	2,34	7,46	17,3	2,73	6,31	17,0	3,11	5,48	16,8	3,49	4,82	16,4	3,83	4,27	16,4	4,33	3,79	16,5	4,83	3,42
	25	-	-	-	17,5	1,94	8,98	17,3	2,32	7,44	17,1	2,66	6,41	16,8	3,07	5,49	16,6	3,44	4,81	16,3	3,82	4,27	16,1	4,21	3,82
30	-	-	-	18,5	1,81	10,2	18,3	2,13	8,59	18,0	2,50	7,22	17,8	2,89	6,18	17,6	3,30	5,33	17,4	3,65	4,76	17,1	3,99	4,29	

9.2 UNIT HEATING SILENCED VERSION

Model i-32V5		HEATING																								
		Header[°C]																								
		25			30			35			40			45			50			55			60			
T outside air [°C]	Thermal power [kW]	Absorbed power [kW]	COP [W/W]	Thermal power [kW]	Absorbed power [kW]	COP [W/W]	Thermal power [kW]	Absorbed power [kW]	COP [W/W]	Thermal power [kW]	Absorbed power [kW]	COP [W/W]	Thermal power [kW]	Absorbed power [kW]	COP [W/W]	Thermal power [kW]	Absorbed power [kW]	COP [W/W]	Thermal power [kW]	Absorbed power [kW]	COP [W/W]	Thermal power [kW]	Absorbed power [kW]	COP [W/W]		
08 SL	-15	6,50	2,18	2,98	6,49	2,39	2,72	6,48	2,60	2,49	6,48	2,79	2,32	6,44	2,94	2,19	-	-	-	-	-	-	-	-	-	-
	-10	6,63	2,02	3,29	6,60	2,19	3,01	6,59	2,44	2,70	6,52	2,63	2,48	6,48	2,79	2,32	6,52	3,02	2,16	6,53	3,34	1,96	-	-	-	-
	-7	6,64	1,90	3,50	6,64	2,09	3,17	6,60	2,29	2,88	6,49	2,42	2,68	6,57	2,71	2,42	6,51	2,88	2,26	6,54	3,13	2,09	6,57	3,37	1,95	-
	-2	5,49	1,35	4,07	5,50	1,51	3,65	5,44	1,65	3,29	5,39	1,77	3,04	5,41	1,97	2,75	5,40	2,12	2,54	5,44	2,33	2,34	5,48	2,54	2,16	-
	2	4,57	0,91	5,02	4,60	1,04	4,43	4,51	1,14	3,96	4,50	1,26	3,58	4,49	1,37	3,27	4,50	1,51	2,98	4,56	1,69	2,69	4,61	1,87	2,46	-
	7	4,54	0,73	6,24	4,56	0,85	5,38	4,58	0,98	4,67	4,52	1,08	4,17	4,45	1,19	3,72	4,43	1,32	3,35	4,43	1,46	3,03	4,43	1,60	2,77	-
	12	4,98	0,62	7,98	4,98	0,73	6,80	4,92	0,84	5,87	4,87	0,95	5,11	4,81	1,06	4,56	4,74	1,18	4,02	4,69	1,31	3,58	4,64	1,44	3,22	-
	15	4,88	0,56	8,72	4,85	0,67	7,29	4,90	0,78	6,28	4,80	0,89	5,41	4,81	1,01	4,77	4,70	1,10	4,26	4,64	1,24	3,75	4,58	1,37	3,34	-
	20	5,01	0,47	10,7	4,96	0,56	8,88	4,94	0,67	7,41	4,81	0,76	6,33	4,80	0,85	5,63	4,83	0,98	4,94	4,73	1,07	4,41	4,63	1,16	3,97	-
	25				5,37	0,50	10,7	5,32	0,61	8,79	5,27	0,71	7,39	5,26	0,82	6,39	5,22	0,94	5,56	5,10	1,04	4,92	4,98	1,13	4,39	-
30				5,46	0,45	12,2	5,44	0,56	9,74	5,37	0,66	8,08	5,30	0,76	6,93	5,26	0,88	5,96	5,21	1,00	5,20	5,16	1,12	4,60	-	
12 SL 12T SL	-15	8,98	3,06	2,93	9,01	3,36	2,68	8,94	3,63	2,47	8,97	3,92	2,29	9,03	4,25	2,12	-	-	-	-	-	-	-	-	-	-
	-10	8,95	2,76	3,25	8,93	3,07	2,91	8,86	3,29	2,70	8,92	3,65	2,44	8,83	3,88	2,27	8,71	4,12	2,11	8,85	4,52	1,96	-	-	-	-
	-7	9,01	2,59	3,47	8,93	2,83	3,15	8,90	3,12	2,85	8,85	3,39	2,61	8,91	3,73	2,39	8,75	3,96	2,21	8,85	4,34	2,04	8,95	4,72	1,90	-
	-2	7,77	1,96	3,96	7,70	2,10	3,66	7,74	2,35	3,30	7,75	2,59	3,00	7,78	2,85	2,73	7,58	3,02	2,51	7,68	3,34	2,30	7,78	3,66	2,12	-
	2	6,78	1,45	4,66	6,73	1,52	4,43	6,82	1,73	3,94	6,87	1,94	3,53	6,88	2,15	3,20	6,65	2,27	2,93	6,75	2,55	2,65	6,84	2,82	2,43	-
	7	7,48	1,33	5,63	7,41	1,34	5,53	7,35	1,52	4,84	7,29	1,68	4,33	7,14	1,85	3,85	7,14	2,05	3,48	7,08	2,28	3,11	7,03	2,51	2,80	-
	12	7,59	1,07	7,12	7,53	1,09	6,92	7,46	1,25	5,95	7,36	1,42	5,18	7,27	1,60	4,55	7,20	1,79	4,02	7,09	1,96	3,62	6,99	2,12	3,29	-
	15	7,61	1,01	7,56	7,54	1,00	7,54	7,47	1,16	6,44	7,39	1,32	5,60	7,32	1,49	4,90	7,23	1,67	4,34	7,12	1,84	3,87	7,00	2,01	3,48	-
	20	7,58	0,88	8,63	7,49	0,84	8,88	7,42	0,98	7,55	7,35	1,12	6,54	7,26	1,29	5,62	7,16	1,44	4,96	7,07	1,60	4,41	6,98	1,76	3,96	-
	25				8,34	0,75	11,1	8,22	0,91	9,08	8,13	1,06	7,64	8,01	1,21	6,60	7,90	1,38	5,71	7,79	1,55	5,03	7,68	1,71	4,49	-
30				9,14	0,69	13,3	9,04	0,78	11,5	8,93	0,94	9,54	8,79	1,09	8,10	8,73	1,26	6,92	8,57	1,39	6,18	8,40	1,51	5,55	-	
16 SL 16T SL	-15	10,3	3,62	2,84	10,2	4,00	2,56	10,2	4,33	2,36	10,2	4,62	2,20	10,8	5,32	2,03	-	-	-	-	-	-	-	-	-	-
	-10	11,9	3,71	3,20	11,8	4,07	2,91	11,8	4,42	2,67	11,8	4,82	2,44	11,6	5,15	2,25	11,6	5,56	2,09	11,3	5,88	1,92	-	-	-	-
	-7	12,3	3,56	3,45	12,2	3,90	3,13	12,0	4,20	2,86	12,0	4,61	2,60	11,9	4,86	2,44	11,8	5,33	2,21	11,8	5,75	2,05	11,8	6,18	1,91	-
	-2	10,7	2,63	4,06	10,7	2,92	3,66	10,6	3,17	3,33	10,6	3,50	3,02	10,6	3,81	2,78	10,5	4,14	2,53	10,5	4,52	2,32	10,5	4,90	2,15	-
	2	9,39	1,88	4,98	9,48	2,14	4,44	9,40	2,35	4,00	9,39	2,61	3,60	9,61	2,98	3,23	9,43	3,19	2,96	9,47	3,53	2,68	9,50	3,87	2,45	-
	7	8,80	1,32	6,67	8,70	1,49	5,84	8,65	1,68	5,15	8,56	1,88	4,56	8,37	2,04	4,10	8,41	2,29	3,66	8,29	2,49	3,32	8,18	2,70	3,04	-
	12	8,44	0,91	9,25	8,37	1,08	7,78	8,29	1,23	6,75	8,20	1,40	5,87	8,12	1,57	5,17	7,95	1,73	4,59	7,85	1,91	4,10	7,75	2,10	3,69	-
	15	8,06	0,77	10,5	8,00	0,90	8,84	7,92	1,05	7,56	7,84	1,20	6,54	7,76	1,35	5,75	7,56	1,49	5,08	7,54	1,66	4,54	7,51	1,83	4,10	-
	20	7,74	0,53	14,5	7,66	0,64	12,0	7,58	0,74	10,2	7,49	0,85	8,76	7,47	0,98	7,64	7,29	1,08	6,77	7,33	1,22	6,01	7,36	1,36	5,40	-
	25				7,90	0,46	17,3	7,88	0,55	14,3	7,76	0,65	12,0	7,65	0,74	10,4	7,63	0,85	9,03	7,44	0,93	7,97	7,25	1,02	7,09	-
30				7,60	0,32	23,7	7,55	0,40	18,9	7,39	0,47	15,6	7,31	0,55	13,2	7,21	0,64	11,3	7,07	0,72	9,84	6,93	0,80	8,66	-	

9.3 COOLING

		COOLING																	
Model i-32V5	T air outdoor [°C]	Tout [°C]																	
		5			7			10			12			15			18		
		Cooling capacity [kW]	Power input [kW]	EER [W/W]	Cooling capacity [kW]	Power input [kW]	EER [W/W]	Cooling capacity [kW]	Power input [kW]	EER [W/W]	Cooling capacity [kW]	Power input [kW]	EER [W/W]	Cooling capacity [kW]	Power input [kW]	EER [W/W]	Cooling capacity [kW]	Power input [kW]	EER [W/W]
04	20	4,11	0,84	4,89	4,41	0,83	5,31	4,90	0,82	5,98	5,00	0,74	6,79	5,14	0,61	8,43	5,61	0,59	9,51
	25	4,13	1,00	4,13	4,45	0,99	4,49	4,96	1,01	4,91	5,03	0,91	5,53	5,13	0,76	6,75	5,69	0,75	7,59
	30	4,11	1,18	3,48	4,46	1,19	3,75	4,95	1,20	4,12	5,02	1,09	4,60	5,13	0,93	5,52	5,68	0,92	6,17
	35	3,94	1,32	2,98	4,33	1,37	3,16	4,86	1,39	3,50	4,94	1,28	3,87	5,07	1,11	4,57	5,59	1,12	4,99
	40	3,76	1,47	2,56	4,07	1,49	2,73	4,56	1,52	3,00	4,64	1,41	3,29	4,77	1,25	3,82	5,28	1,25	4,22
	45	3,50	1,59	2,20	3,78	1,61	2,35	4,25	1,65	2,58	4,33	1,54	2,81	4,45	1,38	3,22	4,93	1,39	3,55
06	20	4,91	1,00	4,90	5,26	1,02	5,13	5,80	1,00	5,80	6,23	0,94	6,63	6,88	0,85	8,09	7,32	0,84	8,71
	25	4,92	1,20	4,10	5,26	1,20	4,40	5,82	1,23	4,75	6,13	1,14	5,38	6,59	1,01	6,52	7,04	0,99	7,11
	30	4,86	1,39	3,49	5,19	1,41	3,69	5,75	1,43	4,03	5,99	1,32	4,55	6,34	1,15	5,51	6,76	1,15	5,88
	35	4,70	1,58	2,98	5,02	1,60	3,14	5,55	1,63	3,40	5,64	1,49	3,79	5,78	1,28	4,54	6,18	1,28	4,82
	40	4,42	1,72	2,57	4,72	1,76	2,69	5,23	1,79	2,92	5,32	1,65	3,23	5,46	1,43	3,82	5,83	1,44	4,05
	45	4,14	1,86	2,22	4,42	1,90	2,32	4,90	1,96	2,51	4,99	1,80	2,77	5,13	1,57	3,27	5,48	1,59	3,45
08 / SL08	20	6,16	1,34	4,62	6,58	1,34	4,91	7,26	1,34	5,43	7,43	1,22	6,09	7,68	1,05	7,34	8,24	1,04	7,90
	25	6,17	1,56	3,96	6,59	1,59	4,15	7,28	1,60	4,55	7,42	1,47	5,06	7,62	1,27	6,02	8,19	1,30	6,33
	30	6,02	1,78	3,39	6,43	1,81	3,55	7,08	1,85	3,82	7,24	1,71	4,23	7,49	1,51	4,97	8,00	1,53	5,24
	35	5,61	1,97	2,86	6,08	1,99	3,05	6,71	2,04	3,28	6,92	1,92	3,60	7,25	1,74	4,17	7,72	1,76	4,38
	40	5,33	2,14	2,50	5,71	2,18	2,62	6,26	2,24	2,80	6,49	2,11	3,07	6,84	1,93	3,54	7,29	1,95	3,73
	45	5,03	2,30	2,19	5,36	2,35	2,28	5,91	2,42	2,44	6,12	2,30	2,66	6,42	2,11	3,05	6,85	2,14	3,20
10 / 10T	20	7,20	1,48	4,86	7,79	1,50	5,20	8,61	1,47	5,85	8,74	1,37	6,36	8,93	1,23	7,29	9,78	1,22	8,00
	25	7,49	1,86	4,04	7,83	1,76	4,46	8,82	1,86	4,73	8,88	1,74	5,11	8,97	1,55	5,79	9,87	1,52	6,49
	30	7,21	2,13	3,39	7,78	2,10	3,71	8,72	2,17	4,02	8,85	2,05	4,32	9,06	1,86	4,86	9,78	1,83	5,35
	35	7,03	2,37	2,97	7,53	2,39	3,15	8,25	2,42	3,41	8,42	2,31	3,64	8,67	2,14	4,05	9,50	2,15	4,41
	40	6,78	2,61	2,59	7,22	2,64	2,73	7,93	2,69	2,95	8,07	2,57	3,14	8,28	2,40	3,45	8,97	2,43	3,70
	45	6,28	2,86	2,19	6,77	2,89	2,34	7,47	2,95	2,54	7,62	2,83	2,70	7,86	2,65	2,97	8,44	2,68	3,15
12 / SL12 / 12T / SL12T	20	8,60	1,89	4,54	9,17	1,85	4,96	10,1	1,84	5,48	10,3	1,71	5,99	10,6	1,53	6,91	11,6	1,54	7,56
	25	8,35	2,09	3,99	8,97	2,14	4,20	10,0	2,16	4,65	10,3	2,05	5,01	10,7	1,89	5,64	11,7	1,89	6,20
	30	8,30	2,43	3,42	8,80	2,41	3,66	9,79	2,49	3,94	10,1	2,37	4,26	10,5	2,19	4,80	11,5	2,21	5,19
	35	7,78	2,74	2,84	8,51	2,79	3,05	9,60	2,86	3,36	10,1	2,82	3,57	10,7	2,75	3,90	11,6	2,79	4,16
	40	7,62	3,02	2,52	8,17	3,07	2,66	8,99	3,15	2,85	9,45	3,11	3,03	10,1	3,06	3,32	10,9	3,10	3,51
	45	7,21	3,29	2,19	7,52	3,33	2,26	8,34	3,42	2,44	8,79	3,39	2,59	9,46	3,35	2,82	10,3	3,41	3,01
14 / 14T	20	10,4	2,02	5,14	11,3	2,05	5,53	12,3	2,02	6,08	13,1	1,87	7,04	14,4	1,64	8,81	15,6	1,61	9,71
	25	10,8	2,51	4,30	11,6	2,51	4,62	12,7	2,55	5,01	13,3	2,30	5,76	14,0	1,93	7,26	15,1	1,89	7,98
	30	11,2	3,07	3,65	12,0	3,19	3,77	13,1	3,23	4,05	13,3	2,85	4,69	13,7	2,27	6,05	14,8	2,26	6,53
	35	10,9	3,48	3,13	11,5	3,53	3,25	12,8	3,59	3,56	12,9	3,19	4,04	13,1	2,58	5,06	14,0	2,59	5,40
	40	10,3	3,80	2,70	10,9	3,88	2,82	11,9	3,96	3,02	12,1	3,53	3,43	12,4	2,89	4,28	13,3	2,91	4,55
	45	9,58	4,12	2,32	10,2	4,20	2,43	11,2	4,30	2,61	11,3	3,86	2,94	11,5	3,19	3,61	12,4	3,23	3,86
16 / SL16 / 16T / SL16T	20	12,1	2,42	5,02	12,9	2,38	5,39	14,1	2,34	6,03	14,5	2,12	6,83	15,1	1,80	8,40	16,2	1,75	9,26
	25	12,1	2,86	4,24	12,9	2,83	4,56	14,3	2,90	4,93	14,5	2,61	5,58	14,9	2,17	6,87	16,0	2,12	7,54
	30	12,8	3,60	3,55	13,6	3,62	3,75	15,0	3,65	4,11	14,9	3,23	4,62	14,7	2,59	5,69	16,0	2,60	6,16
	35	12,9	4,32	2,98	13,8	4,38	3,15	15,1	4,49	3,35	14,9	3,94	3,79	14,8	3,11	4,75	15,8	3,15	5,02
	40	12,2	4,70	2,59	13,1	4,80	2,73	14,2	4,91	2,90	14,1	4,33	3,26	14,0	3,47	4,02	15,0	3,50	4,28
	45	11,4	5,07	2,26	12,2	5,17	2,37	13,6	5,34	2,54	13,3	4,72	2,82	13,0	3,80	3,42	14,0	3,86	3,64
18T	20	13,4	2,68	5,00	14,2	2,72	5,23	15,6	2,72	5,75	15,8	2,42	6,51	16,0	1,98	8,09	17,4	1,99	8,73
	25	13,7	3,30	4,15	14,8	3,41	4,35	16,2	3,38	4,80	16,2	3,03	5,34	16,2	2,52	6,42	17,5	2,49	7,04
	30	14,1	4,00	3,52	15,0	4,11	3,65	16,3	4,00	4,07	16,2	3,58	4,51	16,0	2,95	5,42	17,3	2,99	5,80
	35	14,3	4,81	2,96	15,0	4,88	3,08	16,7	5,01	3,33	16,3	4,43	3,69	15,9	3,56	4,46	17,1	3,59	4,76
	40	13,4	5,21	2,57	14,3	5,32	2,69	15,8	5,47	2,88	15,4	4,86	3,16	14,8	3,94	3,76	16,2	4,00	4,05
	45	12,6	5,63	2,25	13,4	5,73	2,33	14,8	5,92	2,50	14,5	5,28	2,75	14,0	4,33	3,25	15,2	4,40	3,45

## 9.4 SANITARY

The tables show the heating capacity, input power and COP values at various outdoor air temperatures during summer for technical water at 45 / 50 / 55°C for domestic hot water production. The technical data are indicative and are subject to change.

		HEATING								
Model i-32V5	T air outdoor [°C]	Tout [°C]								
		45			50			55		
		Heating capacity [kW]	Power input [kW]	COP [W/W]	Heating capacity [kW]	Power input [kW]	COP [W/W]	Heating capacity [kW]	Power input [kW]	COP [W/W]
04	20	4,66	0,94	4,96	4,59	1,07	4,29	4,54	1,20	3,78
	25	4,86	0,86	5,65	4,80	0,99	4,85	4,72	1,12	4,22
	30	5,21	0,83	6,39	5,18	0,97	5,45	5,11	1,12	4,67
	35	5,64	0,81	7,22	5,61	0,96	6,07	-	-	-
06	20	6,13	1,33	4,61	6,04	1,49	4,04	5,95	1,66	3,59
	25	6,19	1,20	5,16	6,11	1,36	4,48	6,01	1,52	3,94
	30	6,39	1,12	5,70	6,34	1,29	4,90	6,23	1,47	4,25
	35	6,58	1,05	6,27	6,45	1,21	5,34	-	-	-
08 SL08	20	7,66	1,71	4,47	7,58	1,94	3,91	7,50	2,15	3,49
	25	7,76	1,55	4,99	7,73	1,76	4,40	7,60	2,02	3,76
	30	8,17	1,50	5,46	8,10	1,72	4,71	8,03	1,94	4,14
	35	8,55	1,44	5,93	8,43	1,65	5,12	-	-	-
10 10T	20	10,3	2,35	4,36	10,1	2,64	3,83	9,98	2,96	3,37
	25	10,2	2,10	4,84	10,0	2,37	4,24	9,87	2,67	3,70
	30	10,6	2,02	5,25	10,4	2,28	4,55	10,3	2,59	3,96
	35	11,1	1,92	5,78	11,0	2,21	4,97	-	-	-
12 SL12 12T SL12T	20	10,6	2,35	4,50	10,4	2,62	3,97	10,3	2,92	3,52
	25	10,3	2,03	5,08	10,2	2,27	4,46	9,99	2,58	3,87
	30	10,7	1,93	5,56	10,5	2,18	4,82	10,4	2,46	4,22
	35	11,3	1,82	6,17	11,1	2,11	5,25	-	-	-
14 14T	20	14,2	2,61	5,46	14,1	2,93	4,80	13,9	3,25	4,27
	25	14,5	2,27	6,37	14,3	2,57	5,55	14,0	2,86	4,90
	30	15,5	2,06	7,51	15,1	2,38	6,33	14,8	2,69	5,52
	35	16,2	1,90	8,51	15,9	2,21	7,19	-	-	-
16 SL16 16T SL16T	20	14,9	2,79	5,35	14,8	3,13	4,72	14,6	3,48	4,19
	25	14,7	2,31	6,39	14,5	2,64	5,50	14,3	2,94	4,86
	30	15,8	2,18	7,23	15,4	2,46	6,27	15,2	2,76	5,50
	35	16,6	1,98	8,35	16,3	2,25	7,23	-	-	-
18T	20	17,0	3,53	4,82	16,6	3,89	4,26	16,5	4,32	3,81
	25	16,9	3,06	5,54	16,6	3,42	4,86	16,3	3,81	4,28
	30	17,9	2,88	6,20	17,6	3,26	5,39	17,3	3,63	4,76
	35	18,8	2,72	6,93	18,6	3,14	5,94	-	-	-

## 10. DATA FOR THE ENERGY CERTIFICATION OF BUILDINGS ACCORDING TO UNI/TS 11300-4 FOR HEAT PUMPS

Additional data are provided for i-32V5 heat pumps to calculate the energy performance of buildings, according to UNI/TS 11300 part 4. The characteristic values to be provided for each model are shown below.

Legend:

$T_{design}$	Design temperature (for climate A – average, defined by UNI EN 14825 equal to -10°C)
A, B, C, D	Operating conditions of reference to assess performance according to UNI EN 14825
$T_{air}$	Outdoor air temperature of reference
$T_{water}$	Heating water delivery temperature
PLR	Partial Load Ratio - climatic load factor
DC	Declared Capacity - heat pump capacity in operating conditions A, B, C, D
$COP_{DC}$	COP of heat pump referring to nominal DC conditions
$COP_{PL}$	COP of heat pump in partial load conditions defined by standard UNI EN 14825

### Model i-32V504

#### Operating limits

COLD source:		OUTDOOR AIR	
Operating temperature (cut-off)		min	-20°C
		max	30°C
HOT source:		WATER	
(cut-off)		min	25°C
Operating temperature (cut-off)		max	60°C

#### Useful heating capacity / COP in nominal conditions with defrosting contribution

Useful heating capacity [kW]			
$T_{air}$ (cold source)	$T_{water}$ (hot source)		
	35	45	55
-7	3,96	4,02	4,00
2	4,37	4,55	4,29
7	4,76	4,75	4,53
12	4,89	4,89	4,74

$COP_{DC}$			
$T_{air}$ (cold source)	$T_{water}$ (hot source)		
	35	45	55
-7	3,05	2,50	2,12
2	4,05	3,18	2,48
7	4,76	3,65	2,94
12	5,69	4,22	3,31

#### Performance data measured in partial load conditions, according to UNI EN 14825

Operating conditions		F	A (E)	B	C	D
$T_{air}$	[°C]	-10	-7	2	7	12
PLR	[%]	100	88	54	35	15
DC Power (Declared Capacity)	[kW]	3,82	3,88	2,38	2,80	3,28
$COP_{PL}$		2,77	3,01	4,53	5,57	7,01
$COP_{DC}$		2,85	3,05	4,05	4,76	5,69

#### Performance

35 °C		
SCOP	$\eta_s$	Energy class
4,56	179%	A+++

**Model i-32V506**

**Operating limits**

COLD source:		OUTDOOR AIR	
Operating temperature (cut-off)		min	-20°C
		max	30°C
HOT source:		WATER	
Operating temperature (cut-off)		min	25°C
		max	60°C

**Useful heating capacity / COP in nominal conditions with defrosting contribution**

Useful heating capacity [kW]			
T <sub>air</sub> (cold source)	T <sub>water</sub> (hot source)		
	35	45	55
-7	6,00	5,85	5,84
2	6,07	5,77	5,99
7	6,08	5,88	6,03
12	6,57	6,53	6,31

COP <sub>DC</sub>			
T <sub>air</sub> (cold source)	T <sub>water</sub> (hot source)		
	35	45	55
-7	2,86	2,44	2,03
2	3,82	3,06	2,58
7	4,51	3,54	2,82
12	5,25	4,02	3,19

**Performance data measured in partial load conditions, according to UNI EN 14825**

Operating conditions		F	A (E)	B	C	D
T <sub>air</sub>	[°C]	-10	-7	2	7	12
PLR	[%]	100	88	54	35	15
DC Power (Declared Capacity)	[kW]	6,12	6,07	3,68	3,16	3,69
COP <sub>PL</sub>		2,73	2,96	4,36	5,56	7,88
COP <sub>DC</sub>		2,76	2,86	3,82	4,51	5,25

**Performance**

35 °C		
SCOP	η <sub>s</sub>	Energy class
4,46	175%	A+++

**Model i-32V508**

**Operating limits**

COLD source:		OUTDOOR AIR	
Operating temperature (cut-off)		min	-20°C
		max	30°C
HOT source:		WATER	
Operating temperature (cut-off)		min	25°C
		max	60°C

**Useful heating capacity / COP in nominal conditions with defrosting contribution**

Useful heating capacity [kW]			
T <sub>air(cold source)</sub>	T <sub>water (hot source)</sub>		
	35	45	55
-7	6,60	6,57	6,54
2	6,61	6,58	6,67
7	7,81	7,58	7,55
12	8,16	7,98	7,79

COP <sub>DC</sub>			
T <sub>air(cold source)</sub>	T <sub>water (hot source)</sub>		
	35	45	55
-7	2,88	2,42	2,09
2	3,72	3,08	2,53
7	4,38	3,50	2,85
12	5,22	4,05	3,18

**Performance data measured in partial load conditions, according to UNI EN 14825**

Operating conditions		F	A (E)	B	C	D
T <sub>air</sub>	[°C]	-10	-7	2	7	12
PLR	[%]	100	88	54	35	15
DC Power (Declared Capacity)	[kW]	6,52	6,52	3,97	3,14	3,67
COP <sub>PL</sub>		2,70	2,95	4,37	5,55	7,86
COP <sub>DC</sub>		2,70	2,88	3,72	4,38	5,22

**Performance**

35 °C		
SCOP	η <sub>s</sub>	Energy class
4,46	176%	A+++

Model i-32V5SL08

**Operating limits**

COLD source:		OUTDOOR AIR	
Operating temperature (cut-off)		min	-20°C
		max	30°C
HOT source		WATER	
Operating temperature (cut-off)		min	25°C
		max	60°C

**Useful heating capacity / COP in nominal conditions with defrosting contribution**

Useful heating capacity [kW]			
T <sub>air</sub> (cold source)	T <sub>water</sub> (hot source)		
	35	45	55
-7	6,60	6,57	6,54
2	4,51	4,49	4,56
7	4,58	4,45	4,43
12	4,92	4,81	4,69

COP <sub>DC</sub>			
T <sub>air</sub> (cold source)	T <sub>water</sub> (hot source)		
	35	45	55
-7	2,88	2,42	2,09
2	3,96	3,27	2,69
7	4,67	3,72	3,03
12	5,87	4,56	3,58

**Performance data measured in partial load conditions, according to UNI EN 14825**

Operating conditions		F	A (E)	B	C	D
T <sub>air</sub>	[°C]	-10	-7	2	7	12
PLR	[%]	100	88	54	35	15
DC Power (Declared Capacity)	[kW]	6,23	6,43	3,93	3,13	3,65
COP <sub>PL</sub>		2,60	2,97	4,48	5,80	7,36
COP <sub>DC</sub>		2,70	2,88	3,96	4,67	5,87

**Performance**

35 °C		
SCOP	η <sub>s</sub>	Energy class
4,58	180%	A+++

Model i-32V510 and i-32V510T

**Operating Limits**

COLD source:		OUTDOOR AIR	
Operating temperature (cut-off)		min	-20°C
		max	30°C
HOT source:		WATER	
Operating temperature (cut-off)		min	25°C
		max	60°C

**Useful heating capacity / COP in nominal conditions with defrosting contribution**

Useful heating capacity [kW]			
T <sub>air</sub> (cold source)	T <sub>water</sub> (hot source) (sorgente calda)		
	35	45	55
-7	8,3	8,23	8,26
2	9,50	9,41	9,01
7	10,1	9,8	9,7
12	10,7	10,5	10,2

COP <sub>DC</sub>			
T <sub>air</sub> (cold source)	T <sub>water</sub> (hot source)		
	35	45	55
-7	2,90	2,44	2,06
2	3,78	3,03	2,48
7	4,43	3,48	2,78
12	5,14	3,90	3,09

**Performance data measured in partial load conditions, according to UNI EN 14825**

Operating conditions		F	A (E)	B	C	D
T <sub>air</sub>	[°C]	-10	-7	2	7	12
PLR	[%]	100	88	54	35	15
DC Power (Declared Capacity)	[kW]	8,31	8,33	5,34	4,21	4,92
COP <sub>PL</sub>		2,71	2,93	4,32	6,01	8,08
COP <sub>DC</sub>		2,75	2,90	3,78	4,43	5,14

**Performance**

35 °C		
SCOP	η <sub>s</sub>	Energy class
4,53	178%	A+++

Model i-32V512 and i-32V512T

**Operating limits**

COLD source:		OUTDOOR AIR	
Operating temperature (cut-off)		min	-20°C
		max	30°C
HOT source:		WATER	
Operating temperature (cut-off)		min	25°C
		max	60°C

**Useful heating capacity / COP in nominal conditions with defrosting contribution**

Useful thermal power [kW]			
T <sub>air</sub> (cold source)	T <sub>water</sub> (hot source)		
	35	45	55
-7	8,9	8,91	8,85
2	10,3	10,4	10,2
7	11,8	11,5	11,4
12	12,3	12,0	11,7

COP <sub>DC</sub>			
T <sub>air</sub> (cold source)	T <sub>water</sub> (hot source)		
	35	45	55
-7	2,85	2,39	2,04
2	3,71	3,02	2,49
7	4,32	3,44	2,78
12	5,15	3,94	3,14

**Performance data measured in partial load conditions, according to UNI EN 14825**

Operating conditions		F	A (E)	B	C	D
T <sub>air</sub>	[°C]	-10	-7	2	7	12
PLR	[%]	100	88	54	35	15
DC Power (Declared Capacity)	[kW]	8,82	8,86	5,39	4,27	4,86
COP <sub>PL</sub>		2,64	2,88	4,31	5,82	7,81
COP <sub>DC</sub>		2,70	2,85	3,71	4,32	5,15

**Performance**

35 °C		
SCOP	η <sub>s</sub>	Energy class
4,47	176%	A+++

Model i-32V5SL12 and i-32V5SL12T

**Operating limits**

COLD source:		OUTDOOR AIR	
Operating temperature (cut-off)		min	-20°C
		max	30°C
HOT source:		WATER	
Operating temperature (cut-off)		min	25°C
		max	60°C

**Useful heating capacity / COP in nominal conditions with defrosting contribution**

Useful heating capacity [kW]			
T <sub>air</sub> (cold source)	T <sub>water</sub> (hot source)		
	35	45	55
-7	8,90	8,91	8,85
2	6,82	6,88	6,75
7	7,35	7,14	7,08
12	7,46	7,27	7,09

COP <sub>DC</sub>			
T <sub>air</sub> (cold source)	T <sub>water</sub> (hot source)		
	35	45	55
-7	2,85	2,39	2,04
2	3,94	3,20	2,65
7	4,84	3,85	3,11
12	5,95	4,55	3,62

**Performance data measured in partial load conditions, according to UNI EN 14825**

Operating conditions		F	A (E)	B	C	D
T <sub>air</sub>	[°C]	-10	-7	2	7	12
PLR	[%]	100	88	54	35	15
DC Power (Declared Capacity)	[kW]	8,42	8,74	5,33	4,27	4,83
COP <sub>PL</sub>		2,55	2,90	4,42	6,14	8,00
COP <sub>DC</sub>		2,70	2,85	3,94	4,84	5,95

**Performance**

35 °C		
SCOP	η <sub>s</sub>	Energy class
4,58	180%	A+++

**Model i-32V514 and i-32V514T**
**Operating limits**

COLD source:		OUTDOOR AIR	
Operating temperature (cut-off)		min	-20°C
		max	30°C
HOT source:		WATER	
Operating temperature (cut-off)		min	25°C
		max	60°C

**Performance data measured in partial load conditions, according to UNI EN 14825**

Useful heating capacity [kW]			
T <sub>air</sub> (cold source)	T <sub>water</sub> (hot source)		
	35	45	55
-7	10,7	10,7	10,6
2	13,0	12,7	12,4
7	14,1	13,6	13,4
12	14,7	14,4	14,0

COP <sub>DC</sub>			
T <sub>air</sub> (cold source)	T <sub>water</sub> (hot source)		
	35	45	55
-7	2,95	2,44	2,09
2	4,02	3,24	2,71
7	4,85	3,82	3,09
12	5,94	4,52	3,56

**Performance data measured in partial load conditions, according to UNI EN 14825**

Operating conditions		F	A (E)	B	C	D
T <sub>air</sub>	[°C]	-10	-7	2	7	12
PLR	[%]	100	88	54	35	15
DC Power (Declared Capacity)	[kW]	10,5	10,7	6,52	5,78	6,68
COP <sub>PL</sub>		2,69	2,98	4,20	5,98	8,16
COP <sub>DC</sub>		2,73	2,95	4,02	4,85	5,94

**Performance**

35 °C		
SCOP	η <sub>s</sub>	Energy class
4,48	176%	A+++

Model i-32V516 and i-32V516T

**Operating limits**

COLD source:		OUTDOOR AIR	
Operating temperature (cut-off)		min	-20°C
		max	30°C
HOT source:		WATER	
Operating temperature (cut-off)		min	25°C
		max	60°C

**Useful heating capacity / COP in nominal conditions with defrosting contribution**

Useful heating capacity [kW]			
T <sub>air</sub> (cold source)	T <sub>water</sub> (hot source)		
	35	45	55
-7	12,0	11,9	11,8
2	14,1	14,4	14,2
7	16,3	15,8	15,6
12	16,1	15,8	15,3

COP <sub>DC</sub>			
T <sub>air</sub> (cold source)	T <sub>water</sub> (hot source)		
	35	45	55
-7	2,86	2,44	2,05
2	3,88	3,13	2,60
7	4,67	3,72	3,02
12	5,77	4,43	3,51

**Performance data measured in partial load conditions, according to UNI EN 14825**

Operating conditions		F	A (E)	B	C	D
T <sub>air</sub>	[°C]	-10	-7	2	7	12
PLR	[%]	100	88	54	35	15
DC Power (Declared Capacity)	[kW]	11,7	12,0	7,27	5,70	6,67
COP <sub>PL</sub>		2,60	2,88	4,33	5,83	8,12
COP <sub>DC</sub>		2,67	2,86	3,88	4,67	5,77

**Performance**

35 °C		
SCOP	η <sub>s</sub>	Energy class
4,50	177%	A+++

Model i-32V5SL16 and i-32V5SL16T

**Operating limits**

COLD source:		OUTDOOR AIR	
Operating temperature (cut-off)		min	-20°C
		max	30°C
HOT source:		WATER	
Operating temperature (cut-off)		min	25°C
		max	60°C

**Useful heating capacity / COP in nominal conditions with defrosting contribution**

Useful heating capacity [kW]			
T <sub>air</sub> (cold source)	T <sub>water</sub> (hot source)		
	35	45	55
-7	12,0	11,9	11,8
2	9,4	9,6	9,5
7	8,7	8,4	8,3
12	8,3	8,1	7,9

COP <sub>DC</sub>			
T <sub>air</sub> (cold source)	T <sub>water</sub> (hot source)		
	35	45	55
-7	2,86	2,44	2,05
2	4,00	3,23	2,68
7	5,12	4,10	3,32
12	6,75	5,17	4,10

**Performance data measured in partial load conditions, according to UNI EN 14825**

Operating conditions		F	A (E)	B	C	D
T <sub>air</sub>	[°C]	-10	-7	2	7	12
PLR	[%]	100	88	54	35	15
DC Power (Declared Capacity)	[kW]	11,4	11,8	7,25	5,83	6,66
COP <sub>PL</sub>		2,65	2,98	4,56	6,17	8,70
COP <sub>DC</sub>		2,67	2,86	4,00	5,15	6,75

**Performance**

35 °C		
SCOP	η <sub>s</sub>	Energy class
4,72	186%	A+++

**Model i-32V518T**

**Operating limits**

COLD source:		OUTDOOR AIR	
Operating temperature (cut-off)		min	-20°C
		max	30°C
HOT source		WATER	
Operating temperature (cut-off)		min	25°C
		max	60°C

**Useful heating capacity / COP in nominal conditions with defrosting contribution**

Useful heating capacity [kW]			
T <sub>air</sub> (cold source)	T <sub>water</sub> (hot source)		
	35	45	55
-7	12,6	12,5	12,3
2	15,1	14,9	14,7
7	17,9	17,3	17,3
12	18,3	17,7	17,3

COP <sub>DC</sub>			
T <sub>air</sub> (cold source)	T <sub>water</sub> (hot source)		
	35	45	55
-7	2,83	2,37	2,04
2	3,81	3,05	2,63
7	4,40	3,52	2,88
12	5,29	4,14	3,31

**Performance data measured in partial load conditions, according to UNI EN 14825**

Operating conditions		F	A (E)	B	C	D
T <sub>air</sub>	[°C]	-10	-7	2	7	12
PLR	[%]	100	88	54	35	15
DC Power (Declared Capacity)	[kW]	12,8	12,8	7,81	5,75	6,66
COP <sub>PL</sub>		2,59	2,83	4,34	5,67	7,94
COP <sub>DC</sub>		2,66	2,83	3,81	4,40	5,29

**Performance**

35 °C		
SCOP	η <sub>s</sub>	Energy class
4,46	175%	A+++

## 10.1 EER DATA TO CALCULATE THE ENERGY PERFORMANCE OF BUILDINGS, ACCORDING TO UNI/TS 11300-3

The EER coefficients under partial load conditions for i-32V5 reversible heat pumps are provided.

The conditions of reference under partial load specified by standard UNI/TS 11300-3 for air-water reversible chillers and heat pumps are shown below.

The EER are also provided for load factors lower than 25%.

Test	Load factor	Outdoor air dry bulb temperature	Chilled water temperature on fan coil input/output
1	100%	35	12/7
2	75%	30	*)/7
3	50%	25	*)/7
4	25%	20	*)/7

(\*) temperature set by the full load water flow rate

### Model i-32V504

i-32V504			
Outdoor air dry bulb temperature [°C]	Load factor	EER	Cooling capacity [kW]
35	100%	3,16	4,33
30	75%	3,85	3,16
25	50%	4,80	2,67
20	25%	5,81	2,98

C	Load factor	EER @20°C xC
0,95	20%	5,52
0,94	15%	5,46
0,87	10%	5,05
0,71	5%	4,12
0,46	2%	2,67
0,29	1%	1,68

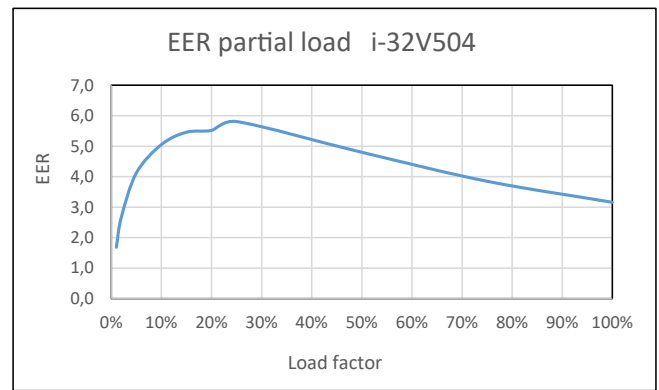

### Model i-32V506

i-32V506			
Outdoor air dry bulb temperature [°C]	Load factor	EER	Cooling capacity [kW]
35	100%	3,14	5,02
30	75%	4,03	3,70
25	50%	4,80	2,70
20	25%	6,10	2,96

C	Load factor	EER @20°C xC
0,95	20%	5,80
0,94	15%	5,74
0,87	10%	5,31
0,71	5%	4,33
0,46	2%	2,81
0,29	1%	1,77

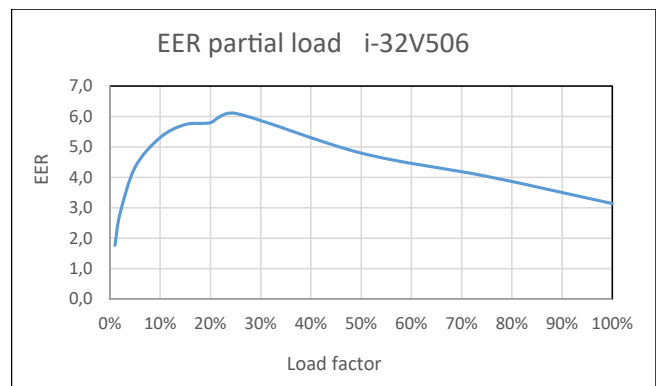

**Model i-32V508, i-32V5SL08**

i-32V508 and i-32V5SL08			
Outdoor air dry bulb temperature [°C]	Load factor	EER	Cooling capacity [kW]
35	100%	3,05	6,08
30	75%	4,07	4,49
25	50%	4,84	2,74
20	25%	6,34	3,02

C	Load factor	EER @20°C xC
0,95	20%	6,02
0,94	15%	5,96
0,87	10%	5,52
0,71	5%	4,60
0,46	2%	2,92
0,29	1%	1,84

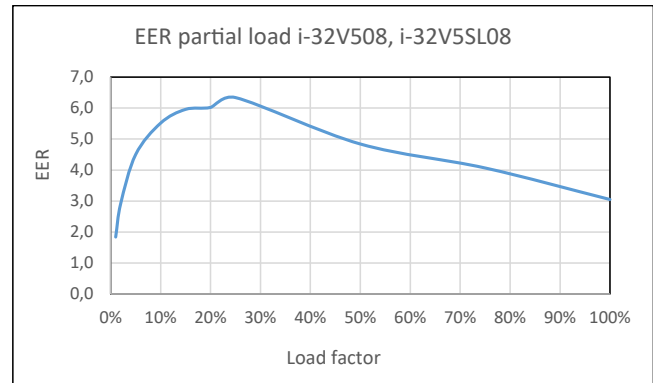

**Model i-32V510 and i-32V510T**

i-32V510 and i-32V510T			
Outdoor air dry bulb temperature [°C]	Load factor	EER	Cooling capacity [kW]
35	100%	3,15	7,49
30	75%	3,92	5,49
25	50%	4,46	3,56
20	25%	6,07	4,35

C	Load factor	EER @20°C xC
0,95	20%	5,77
0,94	15%	5,70
0,87	10%	5,28
0,71	5%	4,31
0,46	2%	2,79
0,29	1%	1,76

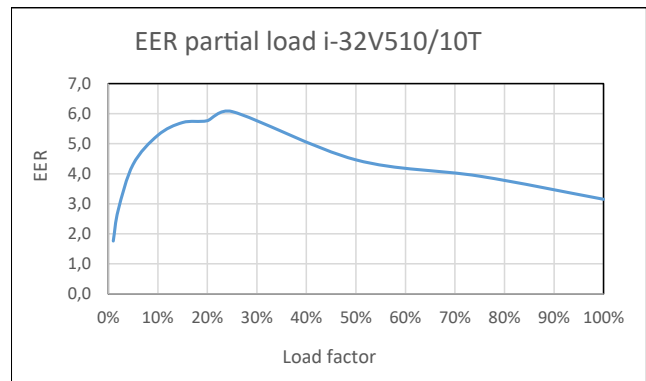

**Model i-32V512,i-32V5SL12,i-32V512T and i-32V5SL12T**

i-32V512,i-32V5SL12,i-32V512T and i-32V5SL12T			
Outdoor air dry bulb temperature [°C]	Load factor	EER	Cooling capacity [kW]
35	100%	3,05	8,51
30	75%	4,03	6,28
25	50%	4,58	3,98
20	25%	6,08	4,23

C	Load factor	EER @20°C xC
0,95	20%	5,77
0,94	15%	5,70
0,87	10%	5,28
0,71	5%	4,31
0,46	2%	2,79
0,29	1%	1,76

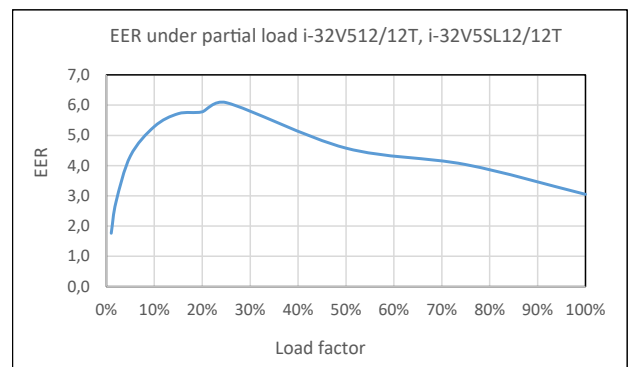

**Model i-32V514 and i-32V514T**

i-32V514 and i-32V514T			
Outdoor air dry bulb temperature [°C]	Load factor	EER	Cooling capacity [kW]
35	100%	3,25	11,5
30	75%	4,31	8,47
25	50%	4,91	5,41
20	25%	6,52	5,53

C	Load factor	EER @20°C xC
0,95	20%	6,20
0,94	15%	6,13
0,87	10%	5,68
0,71	5%	4,63
0,46	2%	3,00
0,29	1%	1,89

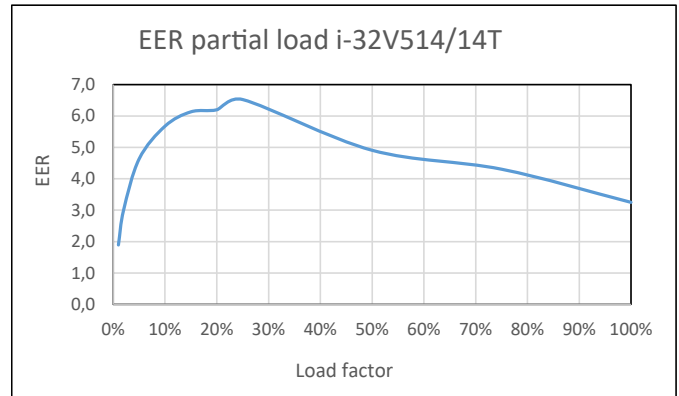

**Model i-32V516,i-32V5SL16 and i-32V516T, i-32V5SL16T**

i-32V516,i-32V5SL16 and i-32V516T, i-32V5SL16T			
Outdoor air dry bulb temperature [°C]	Load factor	EER	Cooling capacity [kW]
35	100%	3,15	13,8
30	75%	4,36	10,02
25	50%	5,30	6,47
20	25%	6,52	5,53

C	Load factor	EER @20°C xC
0,95	20%	6,21
0,94	15%	6,14
0,87	10%	5,68
0,71	5%	4,64
0,46	2%	3,01
0,29	1%	1,89

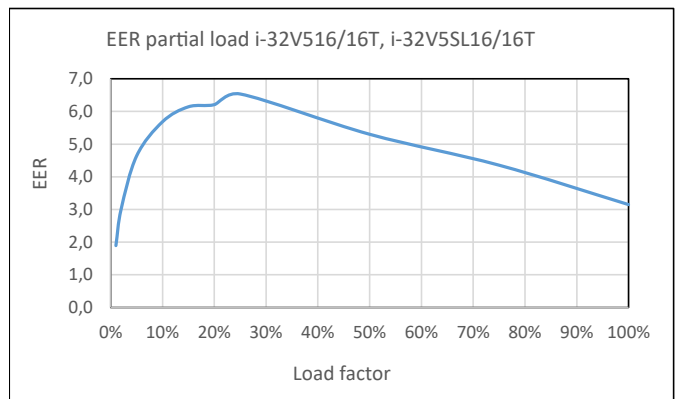

**Model i-32V518T**

i-32V518T			
Outdoor air dry bulb temperature [°C]	Load factor	EER	Cooling capacity [kW]
35	100%	3,08	15,0
30	75%	4,38	11,0
25	50%	5,52	7,06
20	25%	6,68	5,54

C	Load factor	EER @20°C xC
0,95	20%	6,35
0,94	15%	6,28
0,87	10%	5,81
0,71	5%	4,74
0,46	2%	3,07
0,29	1%	1,94

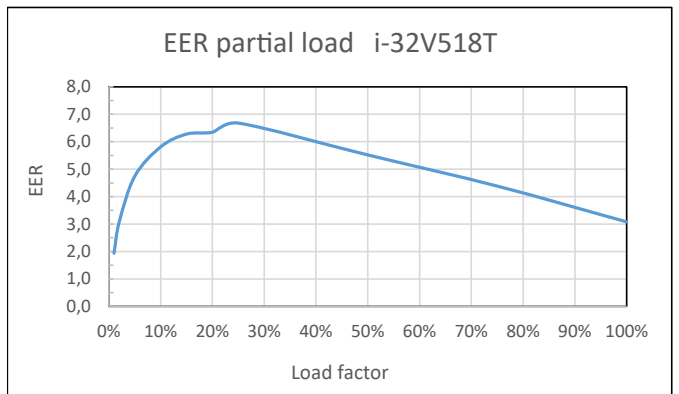

## 11. REFRIGERANT SAFETY DATA SHEET

<b>Name:</b>	R32
<b>HAZARDS IDENTIFICATION</b>	
<b>Main hazards:</b>	Asphyxiation.
<b>Specific hazards:</b>	Quick evaporation could cause it to freeze.
<b>FIRST AID MEASURES</b>	
<b>General information:</b>	Do not administer to people who are unconscious.
<b>Inhalation:</b>	Immediately remove to fresh air. Use oxygen or artificial respiration as required. The use of adrenaline or similar drugs should be avoided.
<b>Eye contact:</b>	Carefully rinse with plenty of water for at least 15 minutes and get medical attention.
<b>Skin contact:</b>	Wash immediately with plenty of water for at least 15 minutes. Apply a sterile gauze. Immediately remove contaminated clothing.
<b>FIRE FIGHTING MEASURES</b>	
<b>Extinguishing media:</b>	Water spray, dry powder.
<b>Specific hazards:</b>	Breakage or explosion of vessel.
<b>Specific methods:</b>	Cool down the containers with a water spray from a safe position. Stop the product leakage if possible. Use water spray, if possible, to abate the fumes. Move the vessels away from the area of the fire if this can be done without posing any risks.
<b>ACCIDENTAL RELEASE MEASURES</b>	
<b>Personal precautions:</b>	Try to stop the leak. Evacuate personnel to safety areas. Ventilate appropriately. Eliminate the ignition sources. Use personal protective equipment.
<b>Environmental precautions:</b>	Try to stop the leak.
<b>Cleaning methods:</b>	Ventilate the area
<b>HANDLING AND STORAGE</b>	
<b>Handling: technical measures/precautions:</b>	Allow efficient air exchange and/or suction the work environments.
<b>Advice for safe use:</b>	Do not breath in fumes or aerosol.
<b>Storage:</b>	Close carefully and store in a cool, dry and well ventilated area. Keep in original containers. Incompatible products: explosive, flammable materials, organic peroxide
<b>EXPOSURE CONTROLS/PERSONAL PROTECTION</b>	
<b>Control parameters:</b>	OEL – data not available. DNEL: Derived no effect level (workers) long-term – systemic effects, inhalation = 7035 mg/m <sup>3</sup> . PNEC: Predicted no-effect concentration water (fresh water) = 0,142 mg/l aquatic, intermittent releases = 1,42 mg/l sediment, fresh water = 0,534 mg/kg dry weight
<b>Respiratory protection:</b>	Not required.
<b>Eye protection:</b>	Safety goggles.
<b>Hand protection:</b>	Latex gloves
<b>Hygienic measures:</b>	No smoking
<b>PHYSICAL AND CHIMICAL PROPERTIES</b>	
<b>Colour:</b>	Colourless.
<b>Odour:</b>	Ethereal. Hard to perceive at low concentrations.
<b>Boiling point:</b>	-51,7 °C at atm press
<b>Flash point:</b>	648 °C
<b>Relative gas density (air=1)</b>	1,8
<b>Relative liquid density (water=1)</b>	1,1
<b>Solubility in water:</b>	280000 mg/l.
<b>STABILITY AND REACTIVITY</b>	
<b>Stability:</b>	Stable under normal conditions.
<b>Materials to avoid: Decomposition products hazardous:</b>	Air, oxidizing agents, humidity. Under normal storage and use conditions, hazardous decomposition products should not be generated..
<b>TOXICOLOGICAL INFORMATION</b>	
<b>Acute toxicity: Local effects: Long term toxicity:</b>	LD/LC50/inHALATION/4 hours/on rat = 1107000 mg/m <sup>3</sup> . No known effect. No kown effect.
<b>ENVIRONMENTAL INFORMATION</b>	
<b>Global warming potential GWP (R744=1):</b>	675
<b>Ozone Depletion Potential ODP (R11=1):</b>	0
<b>Disposal consideration:</b>	Refer to the supplier's gas retrieval program. Avoid direct release into the atmosphere.

**ADVANTIX SpA**

Via S. Giuseppe Lavoratore 24,

37040 Arcole (VR) Italy

Tel. (+39).045.76.36.585

E-mail: [info@advantixspa.it](mailto:info@advantixspa.it)

[www.maxa.it](http://www.maxa.it)

50